

Mini Modbus 1TE

Expansion Module – 1 temperature input, 1 digital output

Version 1.8

User Manual



CE

Manufactured for

aspar

Thank you for choosing our product.

This manual will help you with proper support and proper operation of the device.

The information contained in this manual have been prepared with utmost care by our professionals and serve as a description of the product without incurring any liability for the purposes of commercial law.

This information does not release you from the obligation of own judgment and verification.

We reserve the right to change product specifications without notice.

Please read the instructions carefully and follow the recommendations contained therein.



WARNING!

Failure to follow instructions can result in equipment damage or impede the use of the hardware or software.

1. Safety rules

- Before first use, refer to this manual
- Before first use, make sure that all cables are connected properly
- Please ensure proper working conditions, according to the device specifications (eg: supply voltage, temperature, maximum power consumption)
- Before making any modifications to wiring connections, turn off the power supply

2. Module Features

2.1. Purpose and description of the module

The 1TE module allows you to measure the temperature with attached popular sensor Pt100, Pt500, Pt1000, Ni100, KTY81-110, NTC (Carel) and thermocouple (type J, K, T, N, S, R, B). In addition, it is possible to measure voltages in the range 256mV (10 μ V resolution) and to 2048mV (100 μ V resolution) as well as the measurement of resistance to 8k Ω . In addition, the module has one configurable digital outputs (PNP or NPN).

Values are read via RS485 (Modbus), so we can easily integrate the module with popular PLCs, HMI or PC equipped with the appropriate adapter.

This module is connected to the RS485 bus with twisted-pair wire. Communication is via MODBUS RTU or MODBUS ASCII. The use of 32-bit ARM core processor provides fast processing and quick communication. The baud rate is configurable from 2400 to 115200.

The module is designed for mounting on a DIN rail in accordance with DIN EN 5002.

The module is equipped with a set of LEDs used to indicate the status of inputs and outputs useful for diagnostic purposes and helping to find errors.

Module configuration is done via USB by using a dedicated computer program. You can also change the parameters using the MODBUS protocol.

2.2. Technical Specifications

Power Supply	Voltage	10-38VDC; 20-28 VAC
	Maximum Current	1 W @ 24V DC / 2 VA @ 24V AC
Inputs	No of inputs (TI)	1
	Pt100 operation range	-200°C - +850°C
	Pt500 operation range	-200°C - +850°C
	Pt1000 operation range	-200°C - +850°C
	Ni100 operation range	-60°C - +180°C
	KTY81-110 operation range	-55°C - +150°C
	J thermocouple operation range	-200°C - +1200°C
	K thermocouple operation range	-200°C - +1300°C
	T thermocouple operation range	-200°C - +400°C
	N thermocouple operation range	-200°C - +1300°C
	S thermocouple operation range	-0°C - +1700°C
	R thermocouple operation range	-0°C - +1700°C
	B thermocouple operation range	-0°C - +1800°C
	Resistance	From 0 to 8000Ω (1Ω resolution)
	Voltage	0 to 2048mV (0,1mV resolution) 0 to 256mV (0,01mV resolution)
	Resistance measuring current	~250μA
	Measurement resolution	0,1°C
	Measurement error	±0,5°C
Cold junction temperature measurement	-55°C - +100°C	
Measurement error of the cold junction temperature	±2°C	
ADC processing time	150ms	
Digital outputs	Number of digital outputs	1
	Maximum current	250mA
	Maximum voltage	50V
Environmental conditions	Operating temperature	-10°C - +50 °C
	Storage temperature	-40°C - +85°C
	Relative humidity	5 – 95% RH (without condensation)
	Ingress protection	IP40
Connectors	Power Supply	2 x screw connector
	Communication (RS485)	3 x screw connector
	Inputs and outputs	3 (TI) + 2 (DO) screw connector
	Configuration	Mini USB, type B
	Max. cable size	2,5 mm ² (18...12 AWG)

Housing	Material	Self-extinguishing plastic (PC/ABS)
	Mounting	DIN rail (DIN norma EN 50022)
Dimensions	Height / Depth / Width	90 mm / 56 mm / 17 mm
Interface	RS485	Up to 128 devices
	Communication protocol	Modbus RTU/ASCII, slave

2.3. Dimensions of the product

Look and dimensions of the module are shown below. The module is mounted directly to the rail in the DIN industry standard. Power connectors, communication and IOs are at the bottom and top of the module. USB connector configuration and indicators located on the front of the module.

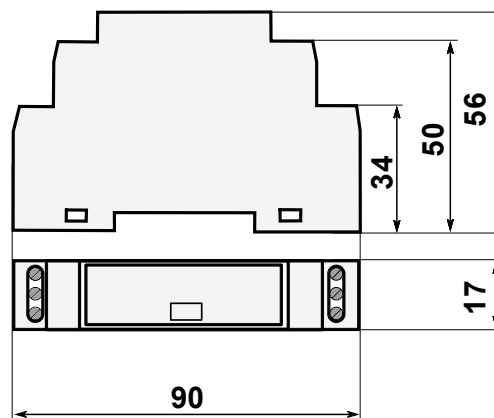

3. Communication configuration

3.1. Grounding and shielding

In most cases, IO modules will be installed in an enclosure along with other devices which generate electromagnetic radiation. Examples of these devices are relays and contactors, transformers, motor controllers etc. This electromagnetic radiation can induce electrical noise into both power and signal lines, as well as direct radiation into the module causing negative effects on the system. Appropriate grounding, shielding and other protective steps should be taken at the installation stage to prevent these effects. These protective steps include control cabinet grounding, module grounding, cable shield grounding, protective elements for electromagnetic switching devices, correct wiring as well as consideration of cable types and their cross sections.

3.2. Network Termination

Transmission line effects often present a problem on data communication networks. These problems include reflections and signal attenuation.

To eliminate the presence of reflections from the end of the cable, the cable must be terminated at both ends with a resistor across the line equal to its characteristic impedance. Both ends must be terminated since the direction of propagation is bi-directional. In the case of an RS485 twisted pair cable this termination is typically 120 Ω.

3.3. Types of Modbus Registers

There are 4 types of variables available in the module

Type	Beginning address	Variable	Access	Modbus Command
1	00001	Digital Outputs	Bit Read & Write	1, 5, 15
2	10001	Digital Inputs	Bit Read	2
3	30001	Input Registers	Registered Read	3
4	40001	Output Registers	Registered Read & Write	4, 6, 16

3.4. Communication settings

The data stored in the modules memory are in 16-bit registers. Access to registers is via MODBUS RTU or MODBUS ASCII.

3.4.1. Default settings

Parameter name	Value
Address	1
Baud rate	19200
Parity	No
Data bits	8
Stop bits	1
Reply Delay [ms]	0
Modbus Type	RTU

3.4.2. Configuration registers

Modbus	Dec	Hex	Name	Values
Address				
40003	2	0x02	Baud rate	0 – 2400 1 – 4800 2 – 9600 3 – 19200 4 – 38400 5 – 57600 6 – 115200 other – value * 10
40005	4	0x04	Parity	0 – none 1 – odd 2 – even 3 – always 1 4 – always 0
40004	3	0x03	Stop Bits LSB	1 – one stop bit 2 – two stop bits
40004	3	0x03	Data Bits MSB	7 – 7 data bits 8 – 8 data bits
40006	5	0x05	Response delay	Time in ms
40007	6	0x06	Modbus Mode	0 – RTU 1 – ASCII

4. Indicators

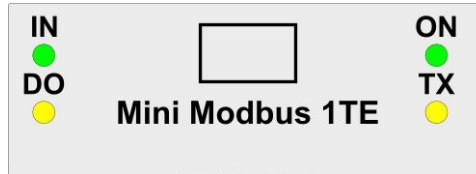

Indicator	Description
ON	LED indicates that the module is correctly powered.
TX	The LED lights up when the unit received the correct packet and sends the answer.
IN	LED indicates that the sensor is connected.
DO	LED indicates that the output is on.

5. Block diagram

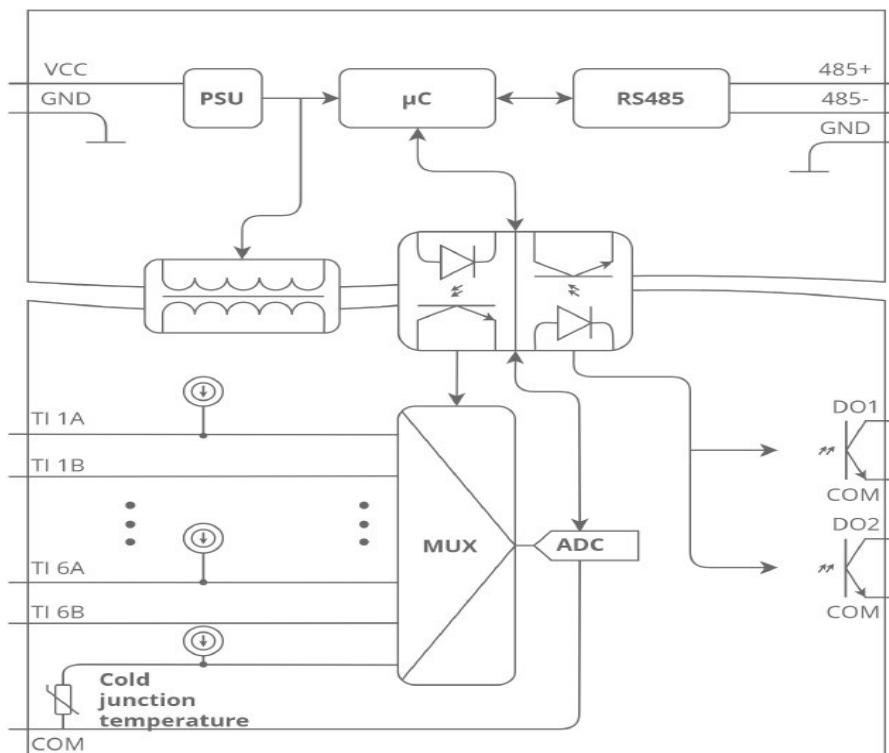

6. Module Connection

6.1. Temperature input, digital output

PT100 2-wire measurement

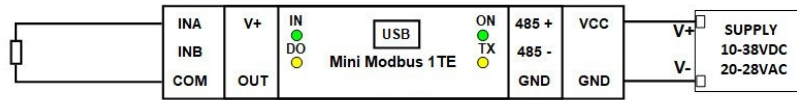

PT100 3-wire measurement

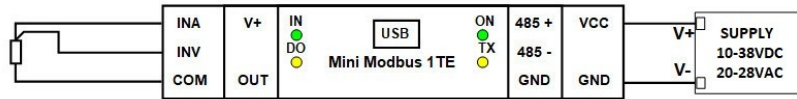

Thermocouple measurement

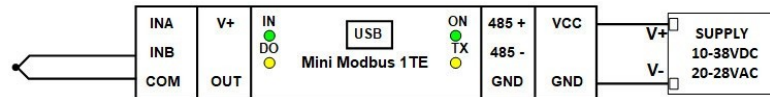

Output connection (NPN type)

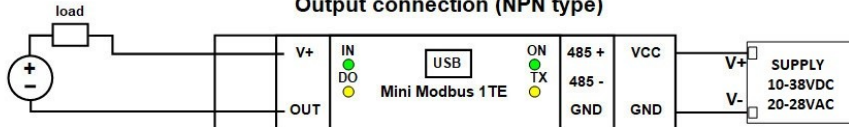

Output connection (PNP type)

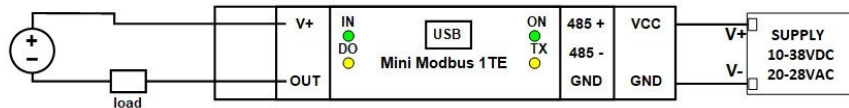

6.2. Communication, power supply

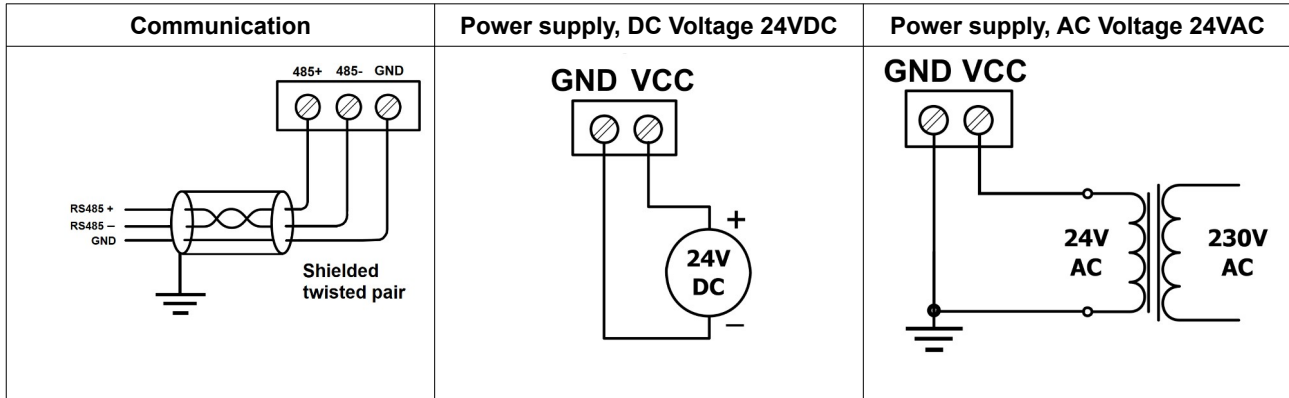

7. Analog Filtering

If the measured signal is interrupted it is possible to eliminate the disruptions by switching the lowpass filter on. It is possible to configure the filter for all inputs (it is not possible to enable the filter for only one input). The filter parameter corresponds to the filter time constant. Step response of the filter is shown in the graph below.

Register: **40010**

Range: **1-10**

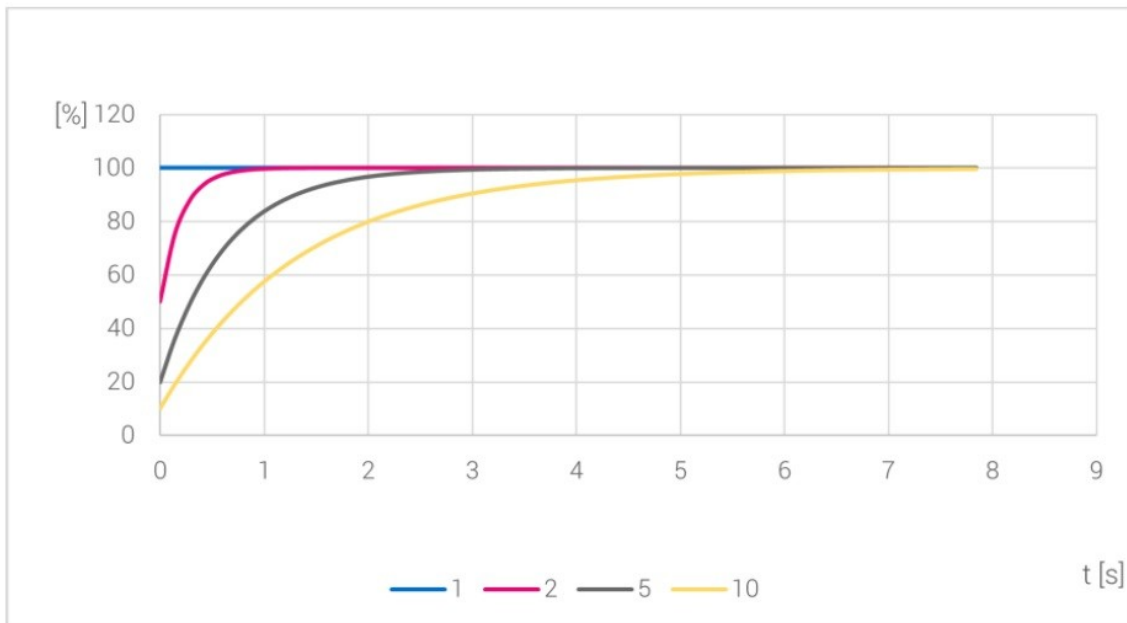

8. Modules Registers

8.1. Registered access

Modbus	Dec	Hex	Register Name	Access	Description
30001	0	0x00	Version/Type	Read	Version and Type of the device
30002	1	0x01	Address	Read	Module Address
40003	2	0x02	Baud rate	Read & Write	RS485 baud rate
40004	3	0x03	Stop Bits & Data Bits	Read & Write	No of Stop bits & Data Bits (see 3.4.2)
40005	4	0x04	Parity	Read & Write	Parity bit
40006	5	0x05	Response Delay	Read & Write	Response delay in ms
40007	6	0x06	Modbus Mode	Read & Write	Modbus Mode (ASCII or RTU)
40010	9	0x09	Analog Filtering	Read & Write	Configuration analog filtering, value from 1 to 10
40033	32	0x20	Received packets LSB	Read & Write	No of received packets
40034	33	0x21	Received packets MSB	Read & Write	
40035	34	0x22	Incorrect packets LSB	Read & Write	No of received packets with error
40036	35	0x23	Incorrect packets MSB	Read & Write	
40037	36	0x24	Sent packets LSB	Read & Write	No of sent packets
40038	37	0x25	Sent packets MSB	Read & Write	
30051	50	0x32	Inputs	Read	Connected sensors Bit in high state → sensor is connected
40052	51	0x33	Outputs	Read & Write	Alarms state bit 2 alarm output
30053	52	0x34	Temperature	Read	Temperature or measured analog in mV·10 for voltage to 2048mV in mV·100 for voltage to 256mV in °C·10 for temperature in Ω for resistance
30054	53	0x35	Junction temperature	Read	Module junction temperature
30055	54	0x36	Measurement current	Read	Measurement current
40056	55	0x37	MAX alarm level	Read & Write	If the temperature exceeds this value the corresponding alarm flag is set
40057	56	0x38	MIN alarm level	Read & Write	If the temperature is below this value corresponding alarm flag is set
40058	57	0x39	Alarm settings	Read & Write	Alarm settings 0 – alarm due to the current temperature 1 – Remember the value of the alarm, until reset by the master via Modbus
40059	58	0x3A	Constant junction temperature	Read & Write	Value of junction temperature
40060	59	0x3B	Junction temperature offset	Read & Write	Junction temperature offset

40061	60	0x3C	Input settings	Read & Write	<p>Analog input mode:</p> <ul style="list-style-type: none"> 0 – input disabled 1 – voltage to 2048mV 2 – voltage to 256mV 3 – J thermocouple 4 – K thermocouple 5 – T thermocouple 6 – N thermocouple 7 – S thermocouple 8 – R thermocouple 9 – B thermocouple 10 – Pt100 3-wire 11 – Pt100 2-wire 12 – resistance to 8kΩ 13 - Ni100 14 – KTY81-110 15 – Pt500 3-wire 16 – Pt500 2-wire 17 – Pt1000 3-wire 18 – Pt1000 2-wire 19 – NTC Carel 2-wire¹ <p>+32 – junction temperature is taken from register 40081 "Constant junction temperature"</p>
40062	61	0x3D	Output settings	Read & Write	<p>Alarm output settings</p> <ul style="list-style-type: none"> 0 – output is set by PLC +256 – Output is set if value is greater than Alarm Value (register 40065) („cooling“) +512 – Output is set if value is less than Alarm Value (register 40065) („heating“)
40063	62	0x3E	Alarm Value	Read & Write	Alarm value for outputs
40064	63	0x3F	Alarm hysteresis	Read & Write	The hysteresis value for alarm outputs
40065	64	0x40	Input resistance	Read & Write	Lead wire resistance for each input

8.2. Bit access

Modbus Address	Dec Address	Hex Address	Register name	Access	Description
801	800	0x320	Input	Read	Set when the sensor is connected
817	816	0x330	Alarm	Read	Alarm state
818	817	0x331	Digital output	Read & Write	State of digital output

¹ Sensor must be connected in parallel to resistor 7.5kΩ 1%

9. Type and version

Information about the type and version of the module is contained in register number 30001. The codes of all available Modbus IO modules are presented below in tabular form, as well as information on how to decode the read value.

Type	Code after conversion	Type	Code after conversion	Type	Code after conversion
MOD-8I8O	0	MOD-1AI	40	SDM-6TE	26
MOD-16I	1	MOD-1TE	41	SDM-16I	12
MOD-16O	2	MOD-4DI	42	SDM-8I8O	11
MOD-6RO	3	MOD-2I2O	43	SDM-16O	14
MOD-8TR	4	MOD-4DO	44	SDM-6RO	15
MOD-16I-M	6	MOD-4DI-M	45	SDM-16RO	16
MOD-16RO	7	MOD-1AO	46	SDM-8AI	22
MOD-8I8RO	8			SDM-8AO	31
MOD-6TE	10				
MOD-8AI	20				
MOD-8AO	30				

Example:

Module **MOD-8I8O**, register value 30001 in decimal system 10240, we convert to hexadecimal system. The value is 28 00. The first bit is the firmware version, in order to read, we convert the hexadecimal value of 28 to the decimal value, ie: 40, divide by 10 and we have the value of firmware **4.0**. The second bit is the version **0** type, ie module MOD-8I8O according to the table.

MOD-4DI-M, 30001 -> 2861 (dec), 0B 2D (hex), 0B (hex)->11(dec) /10 -> 1.1 - firmware version

2D (hex)-> 45 (dec)-> **45** - code MOD-4DI-M

MOD-4DI, 30001 -> 3114 (dec), 0C 2A (hex), 0C (hex)->12(dec) /10 -> 1.2 - firmware version

2A (hex)-> 42 (dec)-> **42** - code MOD-4DI

MOD-2I2O, 30001 -> 7979 (dec), 1F 2B (hex), 1F (hex)->31(dec) /10 -> 3.1 - firmware version

2B (hex)-> 43 (dec)-> **43** - code MOD-2I2O

10. Configuration software

Modbus Configurator is software that is designed to set the module registers responsible for communication over Modbus network as well as to read and write the current value of other registers of the module. This program can be a convenient way to test the system as well as to observe real-time changes in the registers.

Communication with the module is done via the USB cable. The module does not require any drivers.

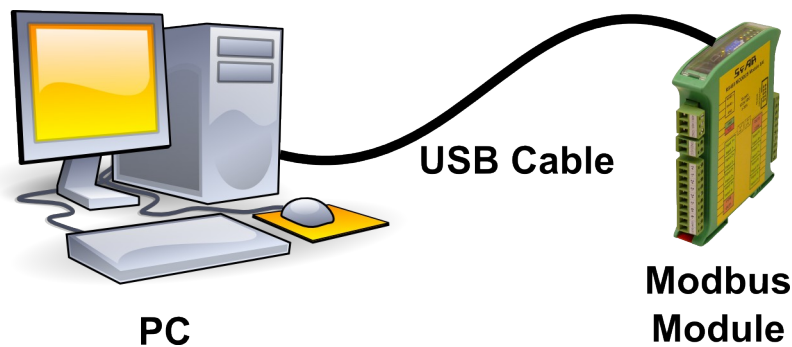

Configurator is a universal program, whereby it is possible to configure all available modules.

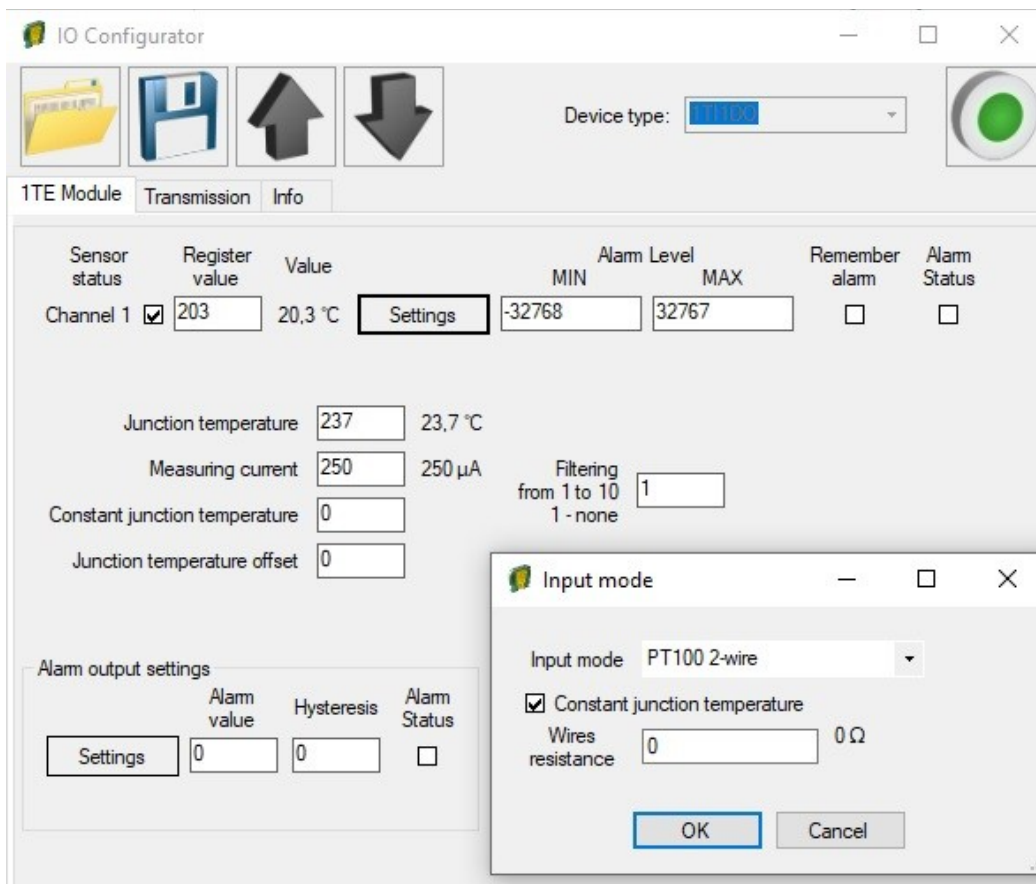

Table of content

1. Safety rules.....	3
2. Module Features.....	3
2.1. Purpose and description of the module.....	3
2.2. Technical Specifications.....	4
2.3. Dimensions of the product.....	5
3. Communication configuration.....	5
3.1. Grounding and shielding.....	5
3.2. Network Termination.....	6
3.3. Types of Modbus Registers.....	6
3.4. Communication settings.....	6
3.4.1. Default settings.....	6
3.4.2. Configuration registers.....	7
4. Indicators.....	8
5. Block diagram.....	8
6. Module Connection.....	9
6.1. Temperature input, digital output.....	9
6.2. Communication, power supply.....	10
7. Analog Filtering.....	10
8. Modules Registers.....	11
8.1. Registered access.....	11
8.2. Bit access.....	12
9. Type and version.....	13
10. Type and version.....	14
11. Configuration software.....	15



Manufactured for:
Aspar s.c.
ul. Oliwska 112
80-209 Chwaszczyno
Poland

ampero@ampero.eu
www.ampero.eu

tel. +48 58 351 39 89; +48 58 732 71 73

