

# OPERATING AND INSTALLATION INSTRUCTIONS COMPACT VENTILATION UNITS LG 350 & LG 450



Z-51.3-428



EN 13141-7:2011

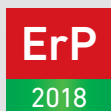

EU-Regulation



EPREL

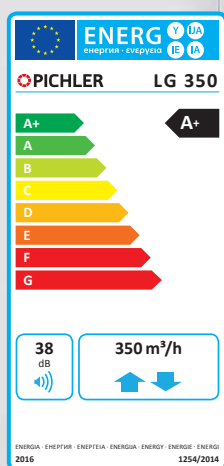

For details – see the brochure



**COMFORT  
VENTILATION**



 **PICHLER**

*Systematic Ventilation.*

## Contents

GENERAL

<b>1. Introduction</b>	<b>Page 4</b>
<b>2. General information</b>	<b>Page 4</b>
<b>3. Function of the ventilation system</b>	<b>Page 5</b>
<b>4. Designated use</b>	<b>Page 5</b>
INTENDED USE	PAGE 5
STIPULATIONS FOR OPERATION WITH FIREPLACES	PAGE 6
STIPULATIONS FOR OPERATION WITH EXTRACTOR HOODS	PAGE 6
LIABILITY	PAGE 7
WARRANTY	PAGE 7

USER

<b>5. Safety</b>	<b>Page 8</b>
SYMBOLS USED	PAGE 8
SAFETY REGULATIONS	PAGE 8
UNIT SET-UP	PAGE 9
ELECTRICAL CONNECTION WORK	PAGE 9
PLANT OPERATION	PAGE 10

### USER GUIDE

<b>6. Customer service</b>	<b>Page 11</b>
<b>7. Design of the ventilation unit</b>	<b>Page 11</b>
<b>8. MINI control unit</b>	<b>Page 12</b>
<b>9. TOUCH control unit</b>	<b>Page 13</b>
<b>10. Faults &amp; messages</b>	<b>Page 22</b>
MINI CONTROL UNIT	PAGE 22
TOUCH CONTROL UNIT	PAGE 22

<b>11. Pichler-App &amp; Pichler Connect</b>	<b>Page 22</b>
EASY OPERATION WITH THE PICHLER APP	PAGE 22
REMOTE ACCESS / PICHLER CONNECT	PAGE 22
PRIVACY	PAGE 23

<b>12. Filter maintenance</b>	<b>Page 23</b>
FILTER MESSAGE ON THE MINI CONTROL UNIT	PAGE 23
FILTER MESSAGE ON THE TOUCH CONTROL UNIT	PAGE 23
FILTER REPLACEMENT	PAGE 24

### SPECIALIST PERSONNEL - MOUNTING / INSTALLATION

<b>13. Scope of supply, transport, storage and disposal</b>	<b>Page 26</b>
SCOPE OF SUPPLY	PAGE 26
TRANSPORT, STORAGE AND PACKAGING	PAGE 26
DISPOSAL	PAGE 26

<b>14. Technical data</b>	<b>Page 27</b>
VERSIONS	PAGE 27
OVERVIEW ENERGY EFFICIENCY CLASSES	PAGE 28
TECHNICAL SPECIFICATIONS	PAGE 29
SOUND DATA	PAGE 30
CHARACTERISTIC CURVE – EXTERNAL PRESSURE INCREASE – AIR VOLUME FLOW	PAGE 31
UNIT DESIGN	PAGE 32
SAFETY DEVICES	PAGE 35

<b>15. System description and expansion options</b>	<b>Page 36</b>
---	----------------

SPECIALIST PERSONNEL



FROST PROTECTION OPTIONS	PAGE 36
SYSTEM EXTENSION FOR EXTERNAL SUPPLY AIR CONDITIONING	PAGE 41
<b>16. TOUCH control unit service level</b>	<b>Page 45</b>
TOUCH CONTROL UNIT TEST MODE	PAGE 45
<b>17. Mounting</b>	<b>Page 46</b>
PREREQUISITES FOR INSTALLATION OF THE UNIT	PAGE 46
OPENING THE UNIT	PAGE 47
UNIT INSTALLATION	PAGE 47
ESTABLISHING THE CONDENSATE DRAIN CONNECTION	PAGE 49
CONNECTING AIR DUCTS AND COMPONENTS	PAGE 50
LEGEND FOR AIR TYPES	PAGE 50
<b>18. Electrical connection</b>	<b>Page 51</b>
OPENING THE UNIT	PAGE 51
CONTROL PCB	PAGE 51
MAINS CONNECTION AND REPLACEMENT OF THE INTERNAL DEVICE FUSING	PAGE 52
ELECTRICAL CONNECTION DIAGRAM	PAGE 52
ELECTRICAL CONNECTION DIAGRAM FOR THE MINI OR TOUCH CONTROL UNIT	PAGE 55
ELECTRICAL CONNECTION DIAGRAM – EXTERNAL INPUTS	PAGE 57
ELECTRICAL CONNECTION DIAGRAM – SHUT-OFF VALVES	PAGE 58
CONNECTING THE CONTROL UNIT TO THE CONTROL PCB	PAGE 59
MOUNTING THE TOUCH CONTROL UNIT	PAGE 59
CIRCULATING PUMPS	PAGE 59
<b>19. Maintenance and cleaning</b>	<b>Page 60</b>
SAFETY INSTRUCTIONS	PAGE 60
MAINTENANCE INSTRUCTIONS	PAGE 60
HEAT EXCHANGER	PAGE 60
FANS	PAGE 61
ELECTRICAL PRE-HEATER BATTERY (OPTIONAL)	PAGE 61
CLEANING THE INSIDE OF THE UNIT HOUSING	PAGE 62
CONDENSATE DRAINAGE	PAGE 62
SERVICE TABLE	PAGE 63
<b>SPECIALIST PERSONNEL - COMMISSIONING – SERVICE</b>	
<b>20. Commissioning</b>	<b>Page 65</b>
BASIC STEPS OF THE COMMISSIONING PROCEDURE	PAGE 65
SETTING SYSTEM PARAMETERS	PAGE 65
<b>21. Error description</b>	<b>Page 66</b>
MINI CONTROL UNIT	PAGE 66
TOUCH CONTROL UNIT	PAGE 66
<b>22. Installation/operation of the service software and firmware updates</b>	<b>Page 66</b>
<b>23. Spare parts and accessories</b>	<b>Page 67</b>
CONTROL ELEMENTS	PAGE 67
SYSTEM COMPONENTS LG 350	PAGE 67
SYSTEM COMPONENTS LG 450	PAGE 67
AIR FILTERS	PAGE 67
ACCESSORIES	PAGE 67
GATEWAY	PAGE 67
<b>24. Changes reserved</b>	<b>Page 67</b>
<b>25. Product data sheets</b>	<b>Page 68</b>
<b>26. EC Declaration of Conformity</b>	<b>Page 72</b>



## 1. Introduction



The compact ventilation units LG 350 and LG 450 employ state-of-the-art technology. They are characterised by cost effectiveness, ease of use and reliability.

To operate your compact ventilation unit safely, properly and economically, please read this manual carefully and follow the instructions provided.

Use the ventilation unit only when in perfect condition and for its designated use, be aware of safety and any hazards and cognisant of all the notes and information contained in this manual.

Should you have any queries or wish to order spare parts, please have the unit

mode and serial number (see nameplate on unit) to hand.

		J. Pichler Gesellschaft m.b.H.		AUSTRIA 9021 KLAGENFURT Karlweg 5 T +43 (0) 463 32769 www.pichlerluft.at	
<b>Equipment type:</b>	08LG350V	<b>Year of manufacture:</b>	XXX		
<b>Serial number:</b>	XXX	<b>Weight:</b>	56 kg		
<b>Order number:</b>	XXX				
<b>Volume flow:</b>	max. 350 m <sup>3</sup> /h				
<b>Dimensions (WxHxD):</b>	829x950x571 mm				
<b>Voltage/frequency:</b>	230V / 50 Hz				
<b>Power consumption:</b>	max. 2050 W				
					 

Please contact us if you have any further questions or if you lose your documentation.

# PICHLER

J. Pichler Gesellschaft m.b.H.

**9021 KLAGENFURT**

Karlweg 5

T +43 (0)463 32769

## 2. General information

This chapter contains some general information about the LG 350 and LG 450 compact ventilation units with the MINI or TOUCH control unit.



**BEFORE COMMISSIONING THE UNIT, PLEASE READ THESE INSTRUCTIONS CAREFULLY!**

This manual contains notes and information on safe operation and proper installation of the LG 350 and LG 450 compact ventilation unit and on its use and servicing. This manual furthermore is to serve as a reference document for servicing to ensure proper execution of the tasks. Keep this operating manual in a safe place and readily available at all times.

Troubleshooting and procedures on the compact ventilation unit may be performed by an installation company (specialist company) only.

### Changes reserved:

This manual has been compiled with the utmost care. This does not, however, imply any rights. We constantly strive to improve and optimise our products technically and we reserve the right to modify our apparatus or technical data fully or in part and without prior notification. Your unit may therefore vary slightly from the description in this manual.

Our "General Terms and Conditions" in their latest version shall apply.



### 3. Function of the ventilation system

With mechanically-controlled residential ventilation, used, damp extract air is conducted away from wet domestic areas, e.g. bathroom, toilet and kitchen, and is replaced with fresh, processed and filtered outdoor air in lounge areas e.g. in living rooms and bedrooms.

Significant energy savings are achieved when the system is operated continuously thanks to highly efficient heat exchangers for heat recovery from extract air to the supply air and the use of energy-efficient

fans with cutting-edge EC technology for air flow control. This technology is particularly effective in air-tight building shells and with active thermal insulation. Heat recovery with an efficiency of over 90 % ensures highly efficient operation.

Protection of the heat exchanger by a suitable closed-loop controlled frost protection mechanism and the provision of an effective condensate discharge are of utmost importance in this respect.

### 4. Designated use

#### INTENDED USE

The LG 350 and LG 450 compact ventilation units are suited for the installation into ventilation and air conditioning systems for the controlled mechanical deaeration and ventilation of homes, large residential units and offices and for similar purposes with an adjustable air volume flow of up to 350 m<sup>3</sup>/h (LG 350) or 450 m<sup>3</sup>/h (LG 450).

The purpose of controlled mechanical ventilation and deaeration of domestic areas is to improve the air quality, to reduce the heating energy demand by the use of a highly efficient heat recovery system, and to influence indoor air humidity.

The unit's fields of application and designated use shall be limited to ventilation and air conditioning systems for the extraction of used air and the supply of fresh, temperature-controlled outdoor air at maximum media temperatures between -15 °C and +35 °C. Furthermore, the extracted air must be free of aggressive vapours and substances causing wear.

Any other use shall be deemed contrary to designated use. The manufacturer shall accept no responsibility for damages or consequential damages arising from improper use. Designated use also includes adherence to our prescribed operating and installation instructions.

This unit is available to the general public and is intended for installation in residential or industrial buildings. The unit is used for mechanical aeration and ventilation of indoor air and, combined with heating or cooling systems, also for auxiliary air heating or cooling.

This unit is not intended for use by persons, including children, with limited physical, sensory or mental capacities or lacking experience and/or knowledge, unless under supervision or instruction of a person responsible for their safety. The unit is not suitable for outdoor installation and may be installed in suitable and frost-free interior areas only. The ventilation unit is not suitable for drying new buildings.



In order to prevent the uncontrolled formation of condensate in the unit, continuous operation with an extract air temperature exceeding 25 °C and an extract air humidity of more than 50 % (e.g. private spa area) is to be avoided at outdoor air temperatures of below 0 °C.



**STIPULATIONS FOR OPERATION WITH FIREPLACES**

The compact ventilation unit is not a ready-to-use product. It must not be put into operation until it has been properly installed and connected to a ventilation system. Only qualified and instructed personnel may work on and with the unit.



Personnel transporting, installing or working on the unit must have read and understood the operating instructions, in particular Section 5, "Safety". The end user must also be instructed on potential hazards.

Local requirements in terms of standards, laws and directives, must be taken into account.



The central air conditioners with heat recovery should not be installed in comparably sized rooms, apartments or facilities with room air dependent heating apparatus unless:

- safety systems are in place to prevent simultaneous operation of room air dependent heating apparatus and units extracting air, or
- special safety systems monitor waste gas extraction of a heating apparatus dependent on room air. Heating apparatus running on liquid or gaseous fuels and drawing in room air, or air conditioning systems, must switch off should a safety system trigger. The air conditioning system must switch off should the safety system trigger in case of solid fuel heating apparatus drawing in room air.

Central air conditioning equipment for controlled ventilation and extraction of air in an apartment or similar facility shall not be installed if the facility has room air dependent heating apparatus connected to waste gas units with multiple infeeds.

For normal operation of central air conditioning systems, it must be possible to close any ducts for combustion air or waste gas systems from heating apparatus dependent on room air. Shutoff systems for waste gas from solid fuel heating apparatus must be manual. The position of the operating lever must indicate the status of the shut-off device. This is deemed complied with if a shut-off system is used to block soot (soot shutoff).

**Fire protection requirements**

The regional regulatory provisions, especially the fire protection regulations for air conditioning of buildings, as amended, must be taken into consideration when installing the air conditioning system in accordance with the instructions for fire protection.

**STIPULATIONS FOR OPERATION WITH EXTRACTOR HOODS**

Due to heavy load and irregular operation, the extract air from any kitchen extractor hoods that may be present must not be integrated into the dwelling's air-conditioning system. Extract air from such extractor hoods must be conducted separately to the outdoors by means of an exhaust air pipe via the roof. The supply air has to be provided separately (e.g. by window ventilation).

If an extractor hood is operated without separate introduction of supply air, air volume in the dwelling becomes unbalanced and proper functioning of the domestic air-conditioning system cannot be guaranteed (odour carryover etc.). Another option is to operate the extractor hood in recirculation mode.



**LIABILITY**

The LG 350 and LG 450 compact ventilation units have been developed and manufactured for controlled mechanical ventilation and deaeration of spaces with purposes similar, for example, to seminar rooms and small offices.

For proper operation of the central air conditioning systems, it must be possible to close any ducts for combustion air and flue gas systems of fireplaces drawing in room air.

Any other use shall be deemed improper and may cause personal injury or damage

to the compact ventilation unit, for which the manufacturer cannot be held liable.

**The manufacturer accepts no responsibility for any damage due to:**

- failure to observe the safety, operating and maintenance instructions provided in this operating and installation manual
- installation of spare parts that have not been supplied by the manufacturer, whereby the system's constructor/installer shall be fully responsible for the use of such spare parts
- normal wear and tear

**WARRANTY**

The warranty period shall commence after the unit is put into operation, but no later than one month after delivery. You can find details on the warrantee in our "General terms and conditions" in the current version and the dealer conditions in your country. The warranty shall be subject to proof of services performed as per our instructions and executed by a licensed installer/specialised company.

Warranty claims shall be limited to material and/or constructional defects occurring during the warranty period. In the event of a warranty claim, the LG 350 and LG 450 compact ventilation unit must not be dismantled without prior written authorisation from the manufacturer. The manufacturer's liability shall be limited

to spare parts installed by an installation company approved by the manufacturer.

The warranty shall automatically lapse at the end of the warranty period, following improper operation such as operation without a filter, if parts other than original manufacturer-supplied parts are installed, or if unauthorised changes or modifications are made to the unit.

The warranty is voided automatically by failure to comply with the information in this installation and operating Manual.

GENERAL

USER

SPECIALIST PERSONNEL



## 5. Safety

Read these operating and installation instructions carefully and observe the notes on safety during installation, commissioning and servicing or general work on the ventilation unit. Keep the Operating and Installation Instructions near the unit for its entire service life.

Always observe the safety regulations, warnings, indications and remarks in these operating instructions. The specifications given in this document must not be altered. Failure to observe these safety

requirements, warning notices, notes and instructions during installation and maintenance works, as well as commissioning, may result in bodily injury or damage to the compact ventilation unit.

The conclusion of a service contract is recommended to ensure that the unit will be inspected at regular intervals. Ask your supplier about approved specialised companies/installers in your area.

### SYMBOLS USED

The following safety symbols highlight text containing warnings in respect of danger and potential hazards. Please familiarise yourself with these symbols.



*Attention/Note!*



**Attention!** Ignoring this warning may lead to injury or threat to life and limb and/or damage to the unit.



**Attention – Hazardous electrical voltage!** Ignoring this warning may lead to injury or threat to life and limb.

### SAFETY REGULATIONS



Installation, initial start-up, maintenance and repairs must be carried out by an authorised specialist company.

Over and above these operating and installation instructions, local and national regulations and standards shall also apply to the operation of this unit without limitation.

Take instruction from your installer on the unit and on its control unit following installation. The ventilation unit may be used only in accordance with the information provided in *Section 4 "Designated Use"*.

All safety and danger notices attached to the unit and mentioned in these instructions must be observed.

In the event of malfunctions, switch off the unit immediately and disconnect the power plug. The ventilation unit must be properly secured against restart. Faults must be remedied immediately.

After repairs and maintenance work, qualified personnel must verify that the unit is safe to operate.

Attachment or installation of additional parts and components is not permitted. Any modification of the compact ventilation unit is prohibited. Only original spare parts may be used.

Modifications and alterations to the ventilation unit are prohibited and absolve the manufacturer from all warranties and liability.

Ensure that children do not play with the unit.



## UNIT SET-UP



National and local regulations must be observed during installation and setup. The unit must be installed in compliance with national installation regulations.

Installation shall be carried out in accordance with the general, locally applicable building, safety and installation regulations of the relevant community or the water and electricity department and other bodies.

The unit may only be installed in frost-free and dry rooms. The room temperature at the place of installation must be consistently between +5°C min. and +35°C max.

The unit is designed for free-standing installation or wall mounting and must only be mounted on a suitable load-bearing structure. The unit must not be exposed to vibration of any kind.

The proper drainage of condensate accumulating during operation of the ventilation unit will be required, including

effective odour blocking traps (siphon). The piping system for water, heating and condensate connections must only be installed by a specialist. The unit must be installed and executed appropriately so as to ensure seal-tightness and effective condensate drainage in order to exclude the possibility of building damage. Effective condensate drainage must be verified on-site prior to initial start-up and after servicing the unit.

The maximum permissible load must be observed when transporting the unit.

Components of the ventilation plant, e.g. air ducts which may need to be installed in unheated areas, must be properly insulated to prevent heat loss or condensate formation (for temperatures under dew point). Observe all locally-applicable construction and fire protection guidelines, regulations and standards. If necessary, appropriate suitable measures must be taken when installing the unit, e.g. the installation of fire dampers in air ducts, etc.

## ELECTRICAL CONNECTION WORK



Warning of hazardous electrical voltage! Disregarding the hazard may result in death, injuries, or damage to material assets. Before carrying out any work on live parts, the unit must always be disconnected completely from the power supply (all poles) and secured against being switched back on.

The earth contact plug and socket-outlet on the power connection makes it possible to disconnect all poles of the unit from the power supply.



Electrical connection work and work on the system's electrical components may be carried out by authorised electricians only, in compliance with national and local regulations.



Before opening the unit and when carrying out work on the unit, e.g. maintenance work and repairs, etc., the unit must be deenergised (disconnection of the voltage supply for

all poles) and must be protected against restart for the duration of the work performed. The compact ventilation unit is designed for a 230 V/50 Hz voltage supply.



Work practices that could compromise the unit's safety are prohibited! To ensure safe operation, safety devices must not be removed or bypassed.

Electrical equipment and the unit's warning and protective devices must be inspected regularly to ensure that they are in perfect working order. In the event of faults in the electrical power supply or the identification of defects, e.g. loose connections or burnt cables, the unit must be switched off immediately.

Damaged or faulty power supply cables to the unit must be repaired immediately to avoid hazards.



## PLANT OPERATION

The unit may not be operated until safe operational conditions are restored.

Fault finding and immediate remediation of electrical defects and malfunctions shall be carried out by authorised electricians only.

All protective measures must be inspected (e.g. earth resistance etc.) after completion of electrical work on the unit. For details, *see Section 17, "Electrical Connection"*.



Operation of the ventilation unit is permitted only if all built-in parts provided, e.g. silencers etc., have been properly connected.

in swimming pools or in areas exposed to chemicals.



In the event of errors or any damage that can cause harm to persons or property, the system must be put out of operation immediately. Further use must be actively prevented until the unit is fully repaired.

Never operate the ventilation unit without an air filter. Air filters must be checked regularly for dirt and damage and replaced, if necessary. The air filters must be changed at least every six months or when the "Change Filter" message appears on the control unit. Use original replacement filters only. If the plant is not used in summer, the air filters must, for hygienic reasons, be replaced prior to restarting.

If error messages occur or any damage is indicated, the ventilation unit must be switched off and disconnected from the power system immediately. Be aware of your safety and of hazards when opening the unit or when removing cover plates. Work practices that could potentially damage the unit are prohibited.

When operating the ventilation unit simultaneously with ambient air-dependent fireplaces, the safety regulations and standards must be complied with. When using fireplaces dependent on ambient air, the combustion air supply must be provided separately. *See the provisions specified in Section 4, "Stipulations for operation with fireplaces"*.



The unit may only be operated with connected air ducts or installed system components such as acoustic dampeners to ensure that fans or electrical components, for instance, cannot be touched by hand.

Due to the heavy impact and inconsistent operation, extractor hoods must in no case be integrated into the exhaust duct of the compact ventilation unit. *See the provisions specified in Section 4, "Provisions in connection with extractor hoods"*. Exhaust air extractor hoods must be operated via separate air pipes with suitable air replenishment, e.g. by means of window ventilation or in air recirculation mode.

The compact ventilation unit may be operated only in accordance with the project documentation, which shall comply with the Equipment and Product Safety Act and the pertinent provisions of the EC Directives and Standards.

Consider environmental impacts and refrain from installing the ventilation unit in the vicinity of flammable liquids or gases,



## USER GUIDE

### 6. Customer service

Please contact the installer of your ventilation and air conditioning system or contact us directly for any questions relating to the LG 350 or LG 450 compact ventilation unit supplied.

 **PICHLER**

J. Pichler Gesellschaft m.b.H.

**9021 KLAGENFURT**

Karlweg 5

T +43 (0)463 32769

GENERAL

USER

SPECIALIST PERSONNEL

### 7. Design of the ventilation unit



The LG 350 and LG 450 compact ventilation units with PHI certificate are used for the controlled mechanical aeration and ventilation of homes, larger residential houses, offices and similar applications and are suited for free-standing installation or wall mounting in frost-free rooms.

Their range of use extends to residential spaces from approx. 100 m<sup>2</sup> to approx. 350 m<sup>2</sup> with a standard room height, in passive or low-energy houses, with an adjustable air volume flow of up to 350 m<sup>3</sup>/h (LG 350) or 450 m<sup>3</sup>/h (LG 450).

Operation is simple and intuitive and, with an Internet connection (LAN connection) can also be carried out via the Pichlerluft app. *For details, see section 11. "Pichler-App & Pichler Connect".*

The optional expansion options by the CO<sub>2</sub> sensor module and the humidity sensor allow for demand-driven ventilation operation.

**The LG 350 and LG 450 compact ventilation units are provided with:**

- a compact, thermal bridge-free and thermally insulated EPP housing
- a device enclosure of galvanised sheet steel, powder-coated in RAL 9003 on the outside
- a highly efficient heat recovery system with an air-to-air counterflow heat exchanger made of recyclable plastic with an efficiency of 93 % in the case of LG 350 and 90 % in the case of LG 450
- optionally with additional moisture recovery

- a 100 % automatic integrated bypass to work around the heat exchanger, if required
- selectable, automatically working frost protection switch for the heat exchanger, optionally available with an electrical pre-heater battery
- energy-saving radial fans in state-of-the-art EC motor technology
- an integrated volume flow measurement, which guarantees balanced operation on the supply and extract air sides. Even if the system pressure is changed, the air volume flow is maintained, e.g. if the filter is contaminated.
- outdoor air filter of quality class ISO ePM1 60 % and extract air of quality class ISO Coarse 80 %
- integrated filter monitoring – when the time interval is reached, the "Filter replacement" message is output on the control unit
- filter replacement can be carried out without tools
- an internally wired electronic controller
- as a standard feature, with the MINI control unit for setting the basic functions
- optionally with the comfortable TOUCH control unit, with an integrated room temperature sensor for enhanced operation and display, as well as with an optional swiveling console. The TOUCH operating control unit can be attached directly to the ventilation unit on a swiveling console.
- optional connection of a heater, cooling or combination battery for the additional conditioning of the supply air



## 8. MINI control unit

### FUNCTIONS



The following compact ventilation unit functions can be configured with the MINI control unit:

- Selection of the "Standby" or "Basic ventilation" operating mode
- Ventilation level of the compact ventilation unit
- Change-over between summer, winter, or automatic operation
- Display of filter replacement messages
- Display of fault messages via LED

### BUTTONS AND LEDS

The ventilation unit is operated by means of four buttons.

#### Summer, winter or automatic operation



The two buttons on the left-hand side switch over between summer, winter or automatic operation.



#### Summer

The summer or bypass operation supports cooling of the living area.

Under certain conditions, the heat exchanger can be avoided by means of the bypass and the cold outdoor air is directly blown into the room.



#### Winter

In winter operation, the outdoor air is always conveyed via the heat exchanger.

#### Automatic operation Switch-on/switch-off

By pressing the [Summer] and [Winter] buttons at the same time, automatic operation is activated, automatically changing between summer and winter operation, depending on the outdoor temperature. Active automatic operation is indicated when the summer and winter LED is lit. By pressing the [Summer] or [Winter] button, automatic operation is deactivated.



## CHANGING THE VENTILATION LEVEL



The two buttons on the right-hand side change the ventilation level of the unit. With the [+] button, the ventilation level is increased until Level III is reached, which corresponds to a boost ventilation process. After one hour of operation in the highest ventilation level, the system automatically returns to the normal setting, Level II. Alternatively, you can stop the boost ventilation mode manually before one hour has passed. Simply press the [-] button on your control unit.

### Standby or basic ventilation

If a ventilation level lower than I is selected, the unit either switches to standby or to basic ventilation operation. *For details, see Section 9, "Ventilation level".*

### LEDs

The different states of the ventilation unit are indicated by LEDs. Three LEDs display the current ventilation level.

The LEDs for summer, winter, or automatic mode are located on the left-hand side, arranged next to the corresponding buttons.

### Filter replacement

The potential need for filter replacement is indicated by the LED on the bottom left. For details regarding the subject of filter replacement, *see Section 12, "Filter maintenance".*

### Error messages

The LED for error messages is located on the bottom right. Please contact your installer! For details with regard to the error messages, *see Section 21, "Error description".*

## 9. TOUCH control unit

### START MENU

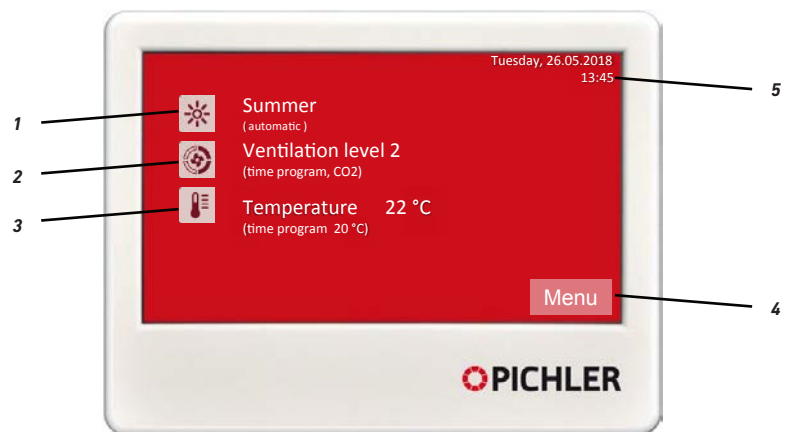

- 1 Current operating mode
- 2 Ventilation level
- 3 Temperature (indoor air, supply air or extract air)

- 4 Menu
- 5 Date and time



**OPERATING MODE**

The active operating mode is displayed by various buttons. The operating mode can be changed by pressing the button. The following operating modes are available:

**Summer**

The summer or bypass mode supports cooling of the living area.

Under certain conditions, the heat exchanger is avoided by means of the bypass and the cold outdoor air is directly blown into the room.

**Winter**

In winter mode, the outdoor air is always conveyed via the heat exchanger.

**Automatic**

In automatic operation, an automatic change-over from summer to winter operation is carried out, depending on the outdoor temperature.

Automatic operation is indicated in brackets below the current operating mode.

**VENTILATION LEVEL**

**The general principle should be observed: "Provide as much ventilation as is necessary"**

Adjusting the air volumes requires the necessary knowledge and is carried out by the specialist during commissioning.

The ventilation levels can be configured in the "Standby" or "Basic ventilation" mode. Depending on these settings, selection of the lowest ventilation level establishes standby or basic ventilation mode.

If ventilation is too low, poor indoor air quality or mould formation may result in living areas.

If ventilation is too high, indoor air may become too dry – particularly in the colder months.

The active ventilation level is displayed by various buttons. The ventilation level can be changed by pressing the button. The following selection options are available:

**Time program**

The system runs at the ventilation level that is currently programmed. The time program can be programmed in the [menu] under [Settings].

Demand-driven air volume control is established on a higher level with both the time program and the manual selection of the ventilation level and with connected and configured CO<sub>2</sub> and/or humidity sensors. Programming is carried out in the [Settings] > [Additional functions] menu item.

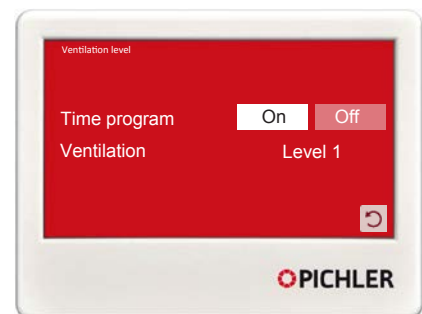

**Manual selection**

When the time program is deactivated [OFF], the ventilation level can be selected manually. This selection is executed via the [+] and [-] buttons and the [OK] button in the lower area of the control unit.

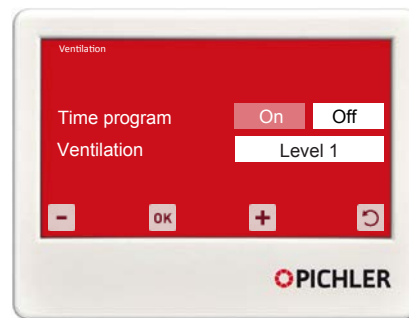
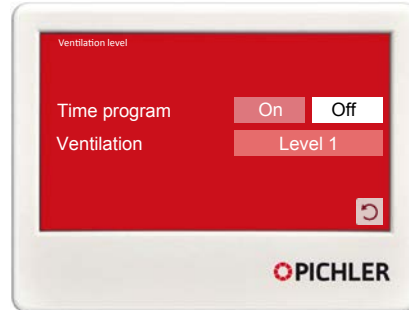

**Standby configuration**

- 

**Ventilation level 1**  
The unit is running in ventilation level 1
- 

**Ventilation level 2**  
The unit is running in ventilation level 2
- 

**Ventilation level 3**  
The unit is running in ventilation level 3

By selecting ventilation level 3, the boost ventilation function is activated. After one hour of operation in the highest ventilation level, the system automatically returns to the ventilation level set previously. Alternatively, you can stop the boost ventilation process manually before one hour has passed by selecting a lower ventilation level.



**Standby**  
The unit is in Standby mode. The fans are not moving.

**Configuration of basic ventilation**



**Ventilation level 1**  
The unit is running in ventilation level 1.



**Ventilation level 2**  
The unit is running in ventilation level 2.



**Ventilation level 3**  
The unit is running in ventilation level 3.

By selecting ventilation level 3, you activate the boost ventilation function. After one hour of operation in the highest ventilation level, the system automatically returns to the ventilation level set previously. Alternatively, you can stop the boost ventilation process manually before one hour has passed by selecting a lower ventilation level.



**Basic ventilation**  
The unit is running with a minimum air volume. The fans are running at a low speed.



**DEMAND-DRIVEN AIR VOLUME CONTROL**

**Higher-level air volume control**

There are various configurations and operating modes that result in your ventilation unit being operated with air volumes other than those set, e.g.:

*CO<sub>2</sub> concentration-based control (Fig. 1)*

Acceptable indoor air should not exceed a CO<sub>2</sub> concentration of 1000 ppm, meaning that active ventilation should take place every 1 to 2 hours. A living room ventilation unit with CO<sub>2</sub> concentration-based control (CO<sub>2</sub> sensor module available as part of the accessories) automatically ensures that a defined CO<sub>2</sub> value of 900 ppm is not exceeded.

*Humidity concentration-based control (Fig. 2)*

The relative humidity is a factor that also contributes significantly to a comfortable living climate. Acceptable humidity is defined by a comfort window.

In the case of a ventilation unit with humidity concentration-based control (RH sensor module available as part of the accessories), a permanently defined **relative humidity** setpoint of **65%** is stored. If this value is exceeded, the ventilation unit switches to the **highest fan level for 60 minutes**.

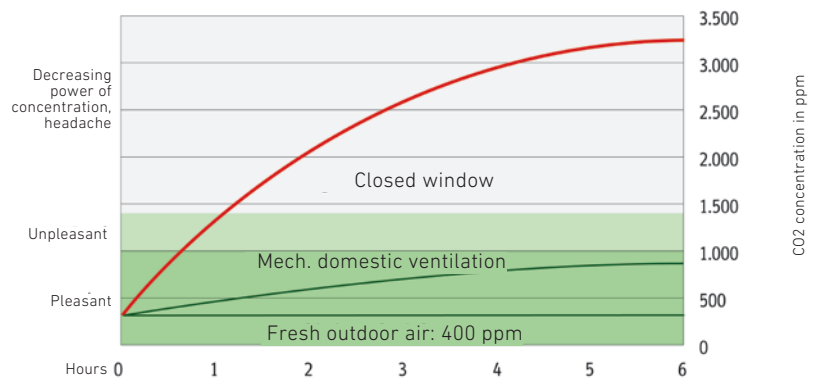

© komfortlüftung.at

**Illustration 1: Schematic diagram showing the increase in CO<sub>2</sub> concentration in a flat/room with occupants with and without mechanical ventilation.**

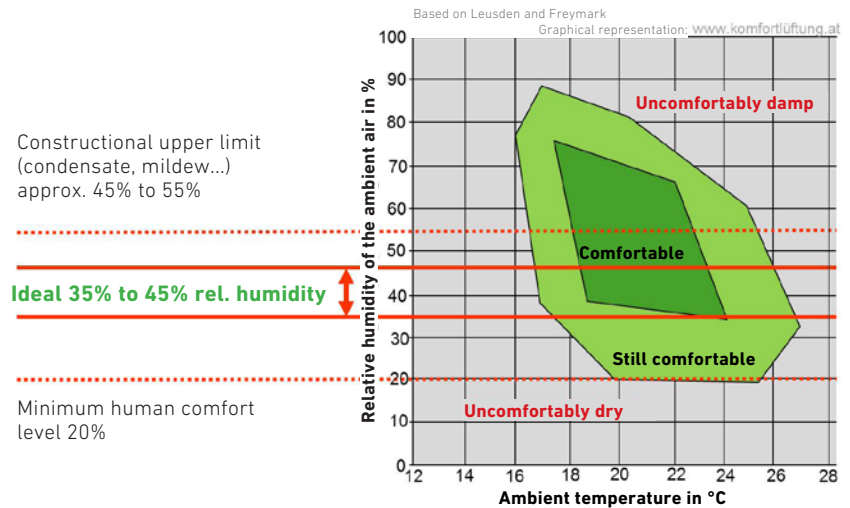

**Illustration 2: Representation of the comfort window as a function of the air temperature and relative humidity.**





**TEMPERATURE**

Depending on the setting, closed-loop control is based on the indoor air, extract air or supply air temperature. The desired temperature can be entered via the control unit. *The "Settings" item under "Temperature control" in Section 9 provides more information on this subject.*

**Deactivated time program [OFF]**

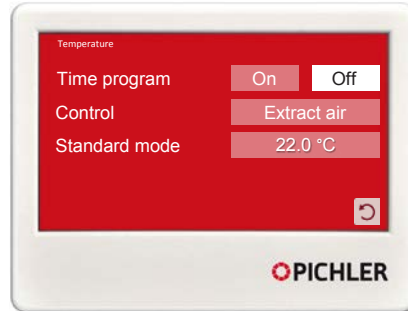

*Setpoint temperature in normal operation.* When the time program is deactivated, this temperature is always the temperature defined for the control process.

**Activated time program [ON] (for different time-of-day setpoint temperatures)**

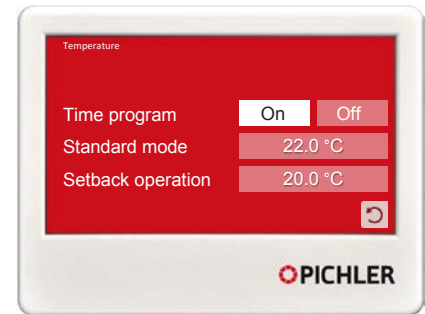

*Setpoint temperature in normal operation and in setback mode.*

When the time program is activated, a switch-over between these two setpoint temperatures is carried out.

 The temperature is controlled in the standard design of the ventilation unit via the integrated bypass circuit and is limited by the outdoor air conditions without the use of the optionally available heater, cooling or combination batteries in the supply air.

**Menu MAIN MENU**



The main menu will open when the Menu button is pressed. Information on the ventilation unit is displayed here, and various settings can be made and actions performed.

 By pressing the Home button you return to the Start menu.





**INFORMATION**

Current operating values, operating hours, messages and firmware versions can be retrieved under the [Information] menu item.

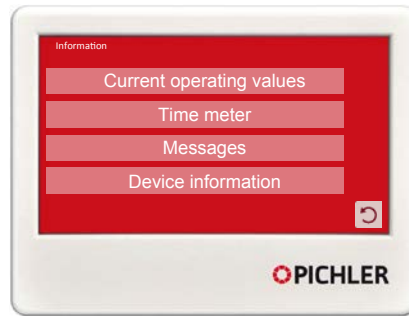

**Current errors**

Active errors are shown here.



**Current operating values**

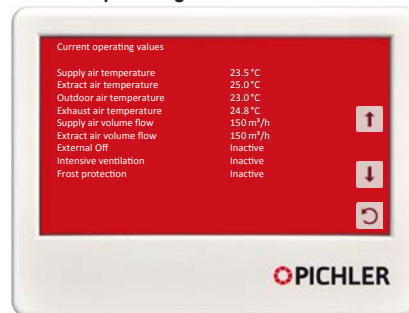

**Error log**

A history of the last 100 errors is listed here.



**Time meter**

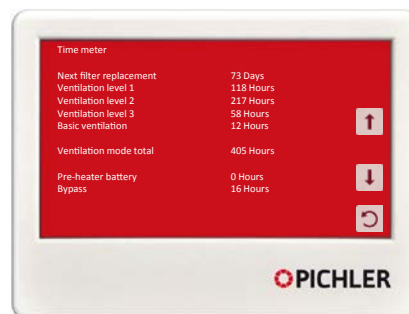

**Filter log**

The filter replacement processes carried out are documented here.



**Messages**

The current errors and error logs, e.g. regarding a filter replacement, are shown here.



**Device information**

Firmware versions used for the controller and control unit as well as the type of ventilation unit are shown here. The device ID shown is relevant for remote access via the Internet (remote maintenance) or when utilising the Pichler app.





**SETTINGS**

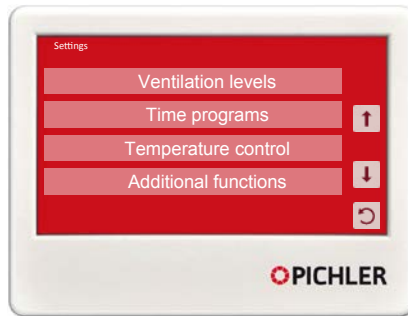

**Volume flow per ventilation level**

The volume flow for each individual ventilation level can be set here.

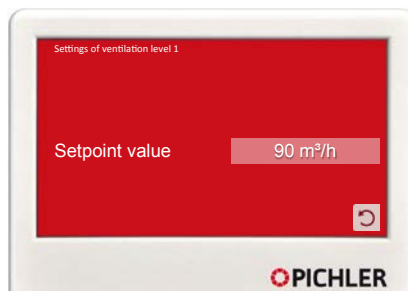
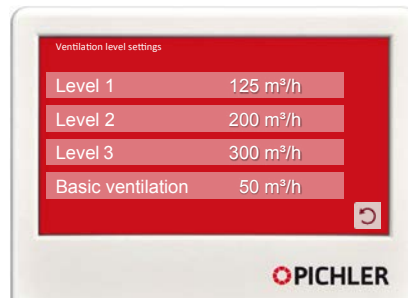

**Time programs**

Various settings for the ventilation level and the temperatures can be carried out for each day of the week.

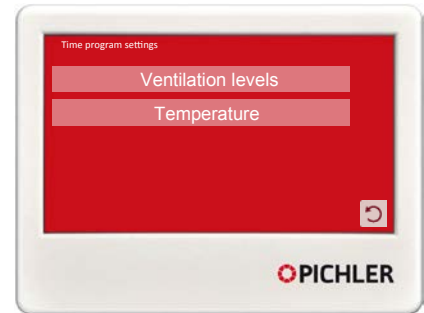

**Time program ventilation level**

A total of three switching times for the change-over to another ventilation level is provided per day. With the "Accept for all days" button, the switching points of the day currently selected can be accepted for all other days of the week. Switching point for operation with ventilation level 3.

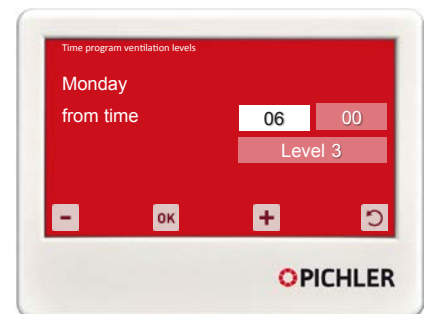
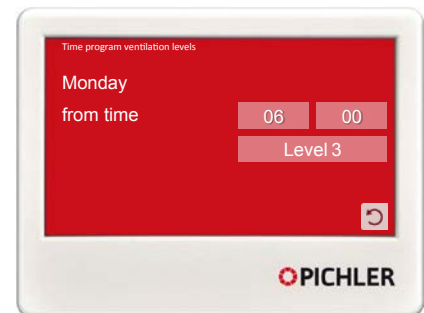
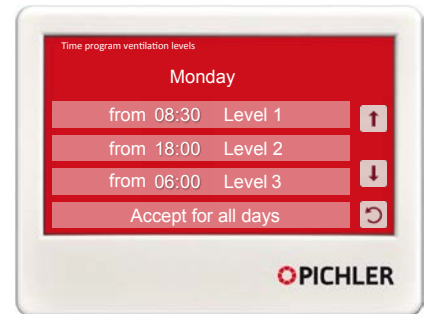

GENERAL

USER

SPECIALIST PERSONNEL



**Time program temperatures**

A total of three switching times for the change-over to another setpoint temperature is provided per day. With the [Accept for all days] button, the switching points of the day currently selected can be accepted for all other days of the week.

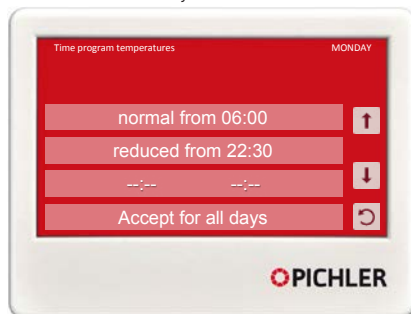

**Heater battery**

Enables re-heating of the supply air downstream of the ventilation unit. This function is only provided in winter operation.

**Cooling battery**

Enables cooling of the supply air downstream of the ventilation unit. This function is only provided in summer operation.

When a combination battery (cooling battery that can also be used for heating) is used, the heater battery and the cooling battery must be activated.

**Date & time**

In this menu item, various date and time settings can be carried out.

**Temperature control**

Depending on the setting, the closed-loop control process is carried out on the basis of the room air, extraction air or supply air temperature.

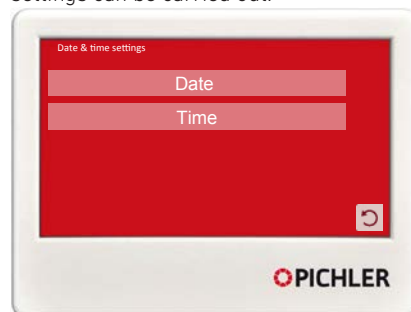

**Date**

In the date field, the current day and month are set. The active field is highlighted in white. By pressing the [+] or [-] button, the value is changed. By pressing the [OK] button, the value is accepted.

**Additional functions**

The additional functions configured by the specialist during commissioning can be activated and deactivated here. The precondition is the installation of the optional sensors or the heater, cooling or combination battery.

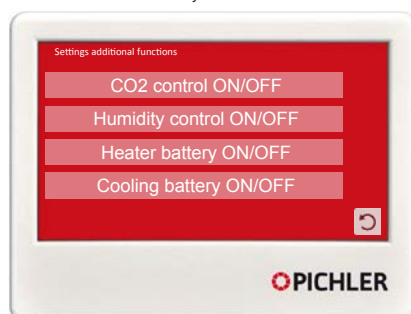

**CO<sub>2</sub> concentration-based control**

Enables the higher-level air volume control as a function of the CO<sub>2</sub> concentration measured.



**Humidity control**

Changes automatically to operation with ventilation level 3 when the relative humidity exceeds 65%.



**Time**



**Language**

The menu is available in German, English, French, Dutch, Slovenian, Italian, Czech and Slovak.



**ACTIONS**



**Air filter changed**



If the air filters are changed outside the filter replacement interval specified, without any filter message, the filter timer should be reset under [Menu] > [Actions]. This process is documented automatically in the filter log.

**Restart device**



If a device restart is required, it can be carried out here. In this process, all settings are maintained. During the restart process, the "Device information" is shown on the control unit.



GENERAL

## 10. Faults & messages

### MINI CONTROL UNIT

The error states of the compact ventilation unit on the MINI control unit are indicated by flashing patterns on the error LED. A detailed description of the flashing codes can be found in *Section 21, "Error description"*.



For further processing, please contact your installer.

USER

### TOUCH CONTROL UNIT



By pressing the [Current errors] button, they are displayed in a new window in clear text.



In addition, the history of these errors is stored in the error log.



If the error is not remedied by a restart of the compact ventilation unit, please contact your installer.

SPECIALIST PERSONNEL

## 11. Pichler-App & Pichler Connect

### EASY OPERATION WITH THE PICHLER APP

*User-friendly:* the compact ventilation unit can be operated easily with our free smartphone app for Android and iOS, whether you are at home or out and about.



### REMOTE ACCESS / PICHLER CONNECT

*Operational safety:* Remote access facilitates a prompt response with minimal effort for the Pichler customer service in the event of a malfunction.



**PRIVACY**

A sticker is attached on the cover of the device. As soon as you establish a cable-controlled Internet connection, we assume your agreement to the current data protection statement. (see: <http://www.pichlerluft.at/data-privacy-statement.html>)

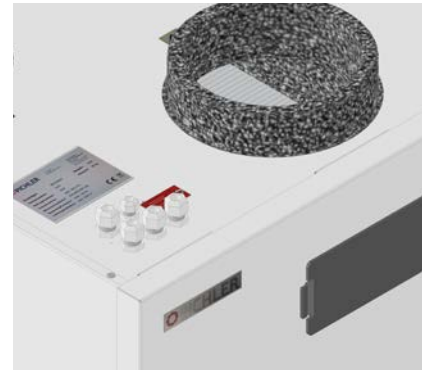

**12. Filter maintenance**

**FILTER MESSAGE ON THE MINI CONTROL UNIT**

When the filter life (factory setting 90 days) has elapsed, the control unit reports the necessity of a filter inspection. This is effected via the LED provided for this purpose, which is then continuously lit in yellow.



**CLEARING THE FILTER MESSAGE ON THE MINI CONTROL UNIT**

**Filter replacement required**  
Reset the filter counter after changing the filter.

In order to do this, also press the [+] and [-] button simultaneously for five seconds.

Press the [+] button and the [-] button at the same time for 5 seconds in order to do this. The filter message disappears after entering this combination.



**Premature filter replacement**  
If the air filters are replaced prematurely, the filter counter must be reset without a pending filter message.

**FILTER MESSAGE ON THE TOUCH CONTROL UNIT**

The control unit will remind you of the necessity of a filter inspection when the filter life (factory setting 90 days) has elapsed. Filters must be replaced immediately if very dirty. Otherwise, they should be replaced at least every six months, depending on outdoor air pollution levels.



**CLEARING THE FILTER MESSAGE ON THE TOUCH CONTROL UNIT**

**FILTER REPLACEMENT**

**Filter replacement required**

When the filters are changed, this must be confirmed via the [Filter changed] button, resetting the filter life.

If the filters remain in the unit, the filter life is extended via the [Remind later] button by a further 90 days.



Only original replacement filters of the specified quality class may be used in the filter replacement process.



When replacing the air filters, avoid soiling the unit and its components. Dirty air filters must be immediately and suitably disposed of. The used air filters can be disposed of as residual waste.

**Premature filter replacement**

Reset the filter signal on the control unit after every filter change! (see Section 9, item "Actions")



Keep the operating time of the compact ventilation unit without air filters as short as possible.

4. If necessary, insert the new air filters and close the filter cover.



*When inserting the new filters, please observe the mounting position (direction of air).*

**Spare filter**

**How to proceed when replacing a filter:**

1. Filter message on control unit.
2. Remove the filter cover (Item 1) by pressing the latches positioned on the sides towards the inside.
3. Pull out the two air filters (Items 2 and 3) by the sleeves.



Symbol	Designation	Item number	Item
	Filter ODA ISO ePM1 60% (outdoor air)	40LG0500001A	2
	Filter ETA ISO Coarse 80% (extract air)	40LG0500000A	3



LEFT-HAND VERSION

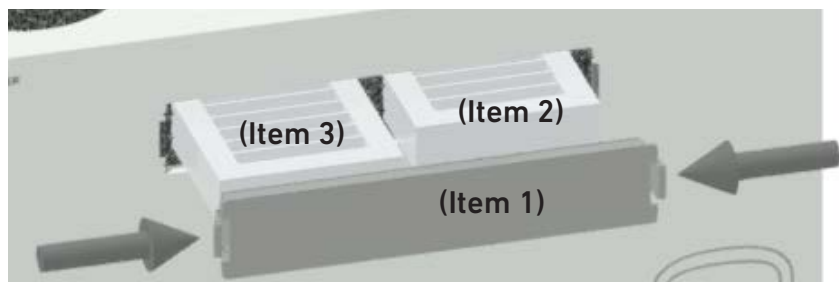

Filter cover (Item 1)

		Filter LG350 / LG450	
		ISO ePM1 60%	
		40LG0500001A	Luftrichtung / Airflow

Outdoor air filter (ODA), installation in the right filter shaft (Item 2)

		Filter LG350 / LG450	
		ISO Coarse 80%	
		40LG0500000A	Luftrichtung / Airflow

Extract air filter (ETA), installation in the left filter shaft (Item 3)

RIGHT-HAND VERSION

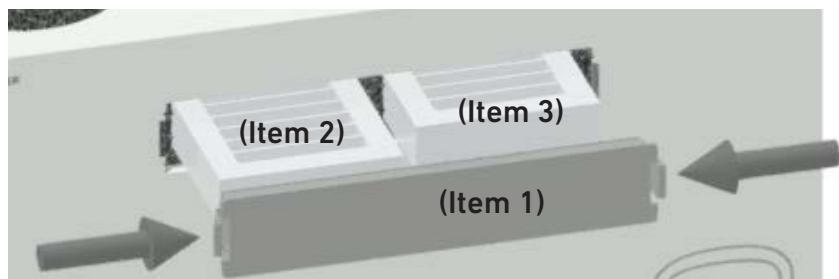

Filter cover (Item 1)

		Filter LG350 / LG450	
		ISO ePM1 60%	
		40LG0500001A	Luftrichtung / Airflow

Outdoor air filter (ODA), installation in the left filter shaft (Item 2)

		Filter LG350 / LG450	
		ISO Coarse 80%	
		40LG0500000A	Luftrichtung / Airflow

Extract air filter (ETA), installation in the right filter shaft (Item 3)

GENERAL

USER

SPECIALIST PERSONNEL



## SPECIALIST PERSONNEL - MOUNTING / INSTALLATION

### 13. Scope of supply, transport, storage and disposal

#### SCOPE OF SUPPLY



#### The scope of supply includes:

- A pluggable compact ventilation unit including a data cable for the control unit
- The MINI or TOUCH control unit (depending on the order)
- The operating and installation instructions

tions

- The wall mounting bracket
- The height-adjustable feet for free-standing installation

On delivery of the unit, check that the type and serial number on the nameplate correspond with the information on the order and delivery documents, that the equipment is complete, including any optional accessories, and that all parts have been delivered in perfect condition.



Any transport damage and/or incomplete delivery must be reported immediately in writing to the forwarder or supplier.

#### TRANSPORT, STORAGE AND PACKAGING



- Dimensions of the packaging unit (W x H x D): 850 x 1100 x 590 mm
- Weight including the packaging unit: approx. 75 kg without optional accessories

In order to avoid potential transport damage, the LG 350 and 450 compact ventilation units must be handled with care and secured accordingly during transport.

Ensure that the unit is not damaged from being toppled or overturned. Avoid knocks and blows during transportation.

Applicable safety and accident regulations must be complied with during transportation.

If transported manually, ensure that necessary human lifting and carrying forces are reasonable.

The compact ventilation unit is supplied in a transport packaging. The safety markings on the packaging must be observed. The unit must be stored in its packaging in suitable, dry rooms.

#### DISPOSAL

The packaging materials must be disposed of in accordance with local regulations; wooden pallets or cartons must be recycled, for instance.







Units that are no longer in working order must be dismantled by a specialised company and properly disposed of via suitable collection centres in accordance with the Waste Electrical and Electronic Equipment Ordinance (WEEE), which provides for the implementation of community law, Directive 2002/95/EC (RoHS) and Directive 2002/96/EC (WEEE Directive).





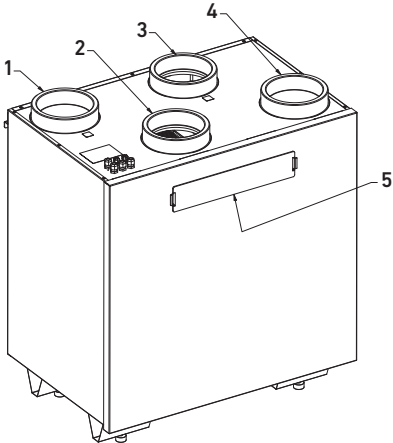
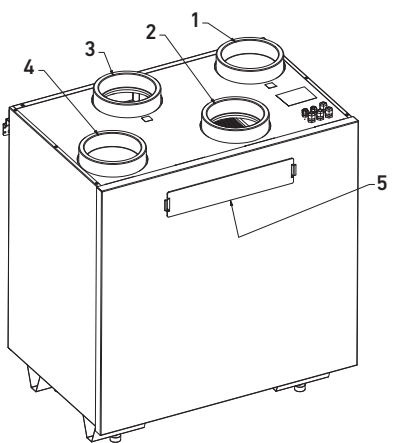

# 14. Technical data

## VERSIONS

### LG 350

Standing or wall-mounted LG 350	Left-hand version	Right-hand version
Item no. without a preheater battery	08LG350L	08LG350R
Item no. with an integrated preheater battery	08LG350LV	08LG350RV
Item no. with enthalpy exchanger	08LG350LF	08LG350RF
Item no. with enthalpy exchanger and an integrated preheater battery	08LG350LFV	08LG350RFV
 1 Supply air  2 Extract air  3 Outdoor air  4 Exhaust air 5 Filter revision		

### LG 450

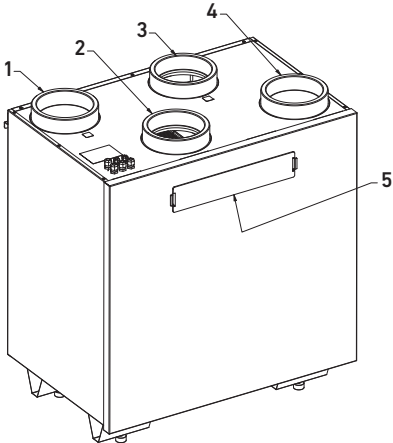
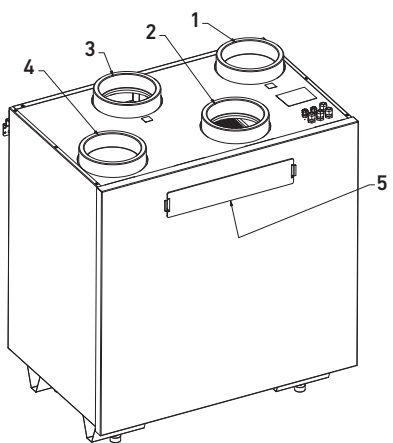
Standing or wall-mounted LG 450	Left-hand version	Right-hand version
Item no. without a preheater battery	08LG450L	08LG450R
Item no. with an integrated preheater battery	08LG450LV	08LG450RV
Item no. with enthalpy exchanger	08LG450LF	08LG450RF
Item no. with enthalpy exchanger and an integrated preheater battery	08LG450LFV	08LG450RFV
 1 Supply air  2 Extract air  3 Outdoor air  4 Exhaust air 5 Filter revision		



OVERVIEW ENERGY EFFICIENCY CLASSES

	LG 350 (V)	LG 350 F (V)	LG 450 (V)	LG 450 F (V)
Manual control	A	A	A	A
Clock control	A	A	A	A
Central demand control	A+	A	A	A
Local demand control	A+	A+	A+	A

Download the product fiches from: [www.pichlerluft.at](http://www.pichlerluft.at)

GENERAL

USER

SPECIALIST PERSONNEL





## TECHNICAL SPECIFICATIONS

Equipment type	LG 350 (V)	LG 350 F (V)	LG 450 (V)	LG 450 F (V)
Heat exchanger	Standard	Enthalpy exchanger	Standard	Enthalpy exchanger
Air volume flow min. - max. (adjustable in steps of 5 m <sup>3</sup> /h)	50 - 350 m <sup>3</sup> /h	50 - 350 m <sup>3</sup> /h	50 - 450 m <sup>3</sup> /h	50 - 450 m <sup>3</sup> /h

Characteristic values in compliance with EN13141-7:2010				
Temperature ratio $\eta_{\theta, SU}^1$	93 %	81 %	91 %	79 %
Temperature ratio $\eta_{\theta, EX}^1$	86 %	75 %	84 %	71 %
Specific input power SIP <sup>1</sup>	0,18 Wh/m <sup>3</sup>	0,16 Wh/m <sup>3</sup>	0,22 Wh/m <sup>3</sup>	0,21 Wh/m <sup>3</sup>
Specific input power SIP <sup>2</sup>	0,19 Wh/m <sup>3</sup>	0,17 Wh/m <sup>3</sup>	0,24 Wh/m <sup>3</sup>	0,21 Wh/m <sup>3</sup>
External leakage	< 0,50 %		< 0,40 %	
Internal leakage	< 0,50 %		< 0,40 %	

Characteristic values in compliance with PHI criteria				
Certified range of application	71 - 277 m <sup>3</sup> /h		71 - 350 m <sup>3</sup> /h	
Heat provision level $\eta_{ef, HR}$ Application range in compliance with PHI	90 %	85 %	89 %	81 %
Moisture recovery	-	76 %	-	76 %
Power efficiency $\eta_{elec}$	0,22 Wh/m <sup>3</sup>	0,22 Wh/m <sup>3</sup>	0,25 Wh/m <sup>3</sup>	0,24 Wh/m <sup>3</sup>
Power consumption in standby operation	3 W			

Classification of air filters in accordance with EN ISO 16890	
 (Filter ODA (Outdoor air))	ISO ePM1 60%
 Filter ETA (Extract air)	ISO Coarse 80%

Operating conditions	
Permissible ambient temperature (place of installation)	+5 to +35 °C
Permissible operating temperature (outside air)	-15 to +35 °C

Electrical system	
Electrical connection	230 V / 1 ~ / 50 Hz / 16 A
IP classification	IP40 with connected air ducts
Max. power without VHR	180 W
Max. power with VHR	2050 W

Materials	
Inner part	EPP and galvanised sheet steel
Housing	Galvanised sheet steel and powder-coated in RAL 9003
Heat exchanger	Polystyrene with flame protection grid
Enthalpy exchanger	Polymer membrane

Housing	
Air duct connections	4 x Ø 160 mm (for steel nipples safe or EPP sleeve DN160)
Condensate drainage	AG 1 1/4"
Dimensions (W x H x D)	829 x 950 x 571 mm
Weight without optional accessories	approx. 56 kg

<sup>1</sup>with 70 % of the max. volume flow<sup>2</sup>in accordance with the calculation basis complying with the specifications of prEN13171-7:2018 relating to an air temperature of 20 °C

SOUND DATA

GENERAL

USER

LG 350		Item	Housing radiation			Outdoor air connector			Supply air inlet			Exhaust air connector			Extract air outlet		
		m <sup>3</sup> /h	245	277	350	245	277	350	245	277	350	245	277	350	245	277	350
		Pa	50	100	100	50	100	100	50	100	100	50	100	100	50	100	100
Midband frequency	125 Hz	L <sub>w</sub> in dB	37	38	41	36	37	39	45	47	50	41	49	51	37	39	44
	250 Hz		46	49	50	43	43	41	55	55	57	51	54	56	43	43	43
	500 Hz		31	34	38	26	30	34	43	46	49	42	45	49	25	28	32
	1000 Hz		27	30	34	23	28	30	40	44	47	40	44	48	23	26	30
	2000 Hz		21	25	30	17	21	26	42	45	50	41	46	50	18	21	26
	4000 Hz		< 15	< 15	19	< 15	< 15	< 15	33	38	44	32	38	44	< 15	< 15	17
	8000 Hz		< 15	< 15	< 15	< 15	< 15	< 15	23	29	36	21	28	37	< 15	< 15	< 15
	Total L <sub>WA</sub> in dB(A)		38	41	45	34	36	37	49	52	56	47	51	55	33	36	38

Note: Tolerances for sound data ± 2 dB, measured in compliance with EN ISO 9614-2

LG 450		Item	Housing radiation			Outdoor air connector			Supply air inlet			Exhaust air connector			Extract air outlet		
		m <sup>3</sup> /h	315	350	450	315	350	450	315	350	450	315	350	450	315	350	450
		Pa	50	100	100	50	100	100	50	100	100	50	100	100	50	100	100
Midband frequency	125 Hz	L <sub>w</sub> in dB	41	43	44	39	44	47	49	51	51	51	52	60	44	44	47
	250 Hz		50	51	50	43	42	44	56	57	61	53	56	61	44	43	45
	500 Hz		37	40	52	32	35	43	48	50	70	48	49	64	31	33	41
	1000 Hz		32	33	40	30	32	36	45	48	52	46	48	55	30	31	36
	2000 Hz		27	30	35	25	28	32	48	50	55	48	51	56	25	27	32
	4000 Hz		< 15	19	26	< 15	16	22	40	44	51	41	44	52	16	19	24
	8000 Hz		< 15	< 15	< 15	< 15	< 15	< 15	32	37	46	33	38	47	< 15	< 15	17
	Total L <sub>WA</sub> in dB(A)		43	45	49	37	38	43	53	56	67	53	56	63	37	39	42

Note: Tolerances for sound data ± 2 dB, measured in compliance with EN ISO 9614-2

SPECIALIST PERSONNEL

Technical specifications LG 350 (V)

PASSIVE HOUSE CERTIFIED IN ACCORDANCE WITH PHI CRITERIA

Degree of heat provision:  $\eta_{\text{Ht, LWRG}} = 90\%$

Comfort criterion:  $T_{\text{SUP}} = +16,5\text{ °C}$  bei  $T_{\text{ODA}} = -10\text{ °C}$

Flow efficiency:  $\eta_{\text{elec}} = 0,22\text{ Wh/m}^3$



Technical specifications LG 350 F (V) with moisture recovery

PASSIVE HOUSE CERTIFIED IN ACCORDANCE WITH PHI CRITERIA

Degree of heat provision:  $\eta_{\text{Ht, LWRG}} = 85\%$

Average moisture ratio:  $\eta_x = 0,76$

Comfort criterion:  $T_{\text{SUP}} = +16,5\text{ °C}$  bei  $T_{\text{ODA}} = -10\text{ °C}$

Flow efficiency:  $\eta_{\text{elec}} = 0,22\text{ Wh/m}^3$



Technical specifications LG 450 (V)

PASSIVE HOUSE CERTIFIED IN ACCORDANCE WITH PHI CRITERIA

Degree of heat provision:  $\eta_{\text{Ht, LWRG}} = 89\%$

Comfort criterion:  $T_{\text{SUP}} = +16,5\text{ °C}$  bei  $T_{\text{ODA}} = -10\text{ °C}$

Flow efficiency:  $\eta_{\text{elec}} = 0,25\text{ Wh/m}^3$



Technical specifications LG 450 F (V) with moisture recovery

PASSIVE HOUSE CERTIFIED IN ACCORDANCE WITH PHI CRITERIA

Degree of heat provision:  $\eta_{\text{Ht, LWRG}} = 81\%$

Average moisture ratio:  $\eta_x = 0,76$

Comfort criterion:  $T_{\text{SUP}} = +16,5\text{ °C}$  bei  $T_{\text{ODA}} = -10\text{ °C}$

Flow efficiency:  $\eta_{\text{elec}} = 0,24\text{ Wh/m}^3$



**CHARACTERISTIC CURVE –  
EXTERNAL PRESSURE INCREASE –  
AIR VOLUME FLOW**

The characteristic curves shown are applicable to unit type with a filter ODA ISO ePM1 60 % (outdoor air) and a filter ETA ISO Coarse 80 % (extract air) and with an electrical pre-heater battery.

The total power specified takes the power consumption for the two fans in the supply air and exhaust air as well as the power consumption of the controller into consideration.

GENERAL

USER

SPECIALIST PERSONNEL

External pressure increase - air volume flow

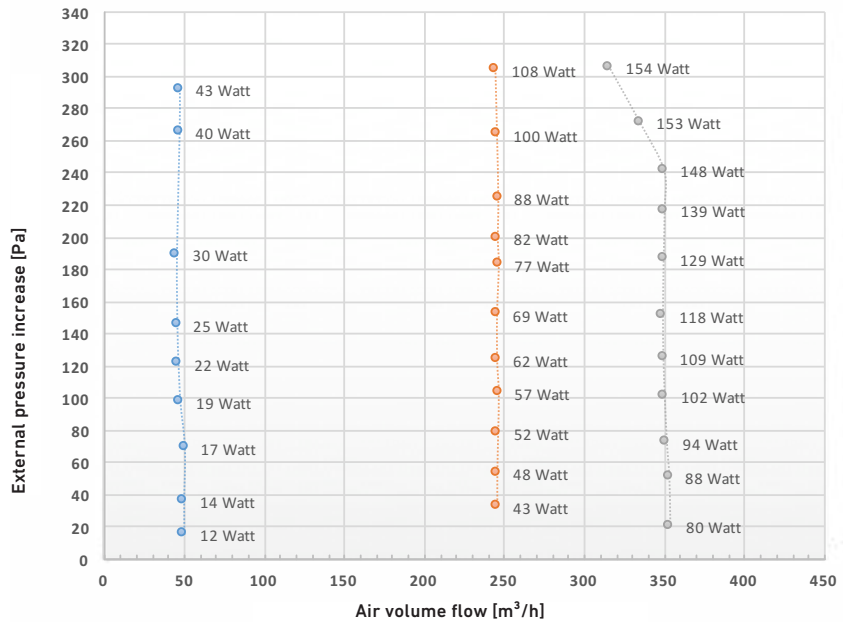

LG 350 V compact ventilation unit

External pressure increase - air volume flow

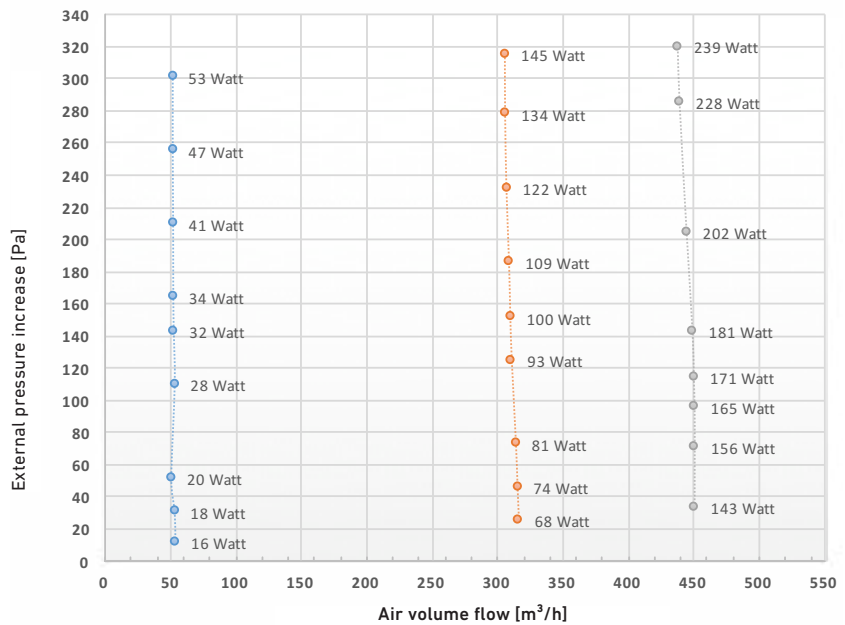

LG 450 V compact ventilation unit



**Note!** Depending on the installed air duct system, the maximum air volume flow may not be achieved in bypass mode.



GENERAL

USER

UNIT DESIGN

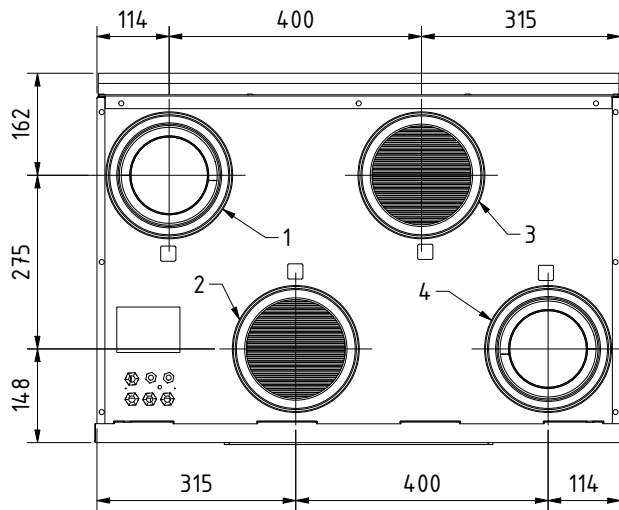
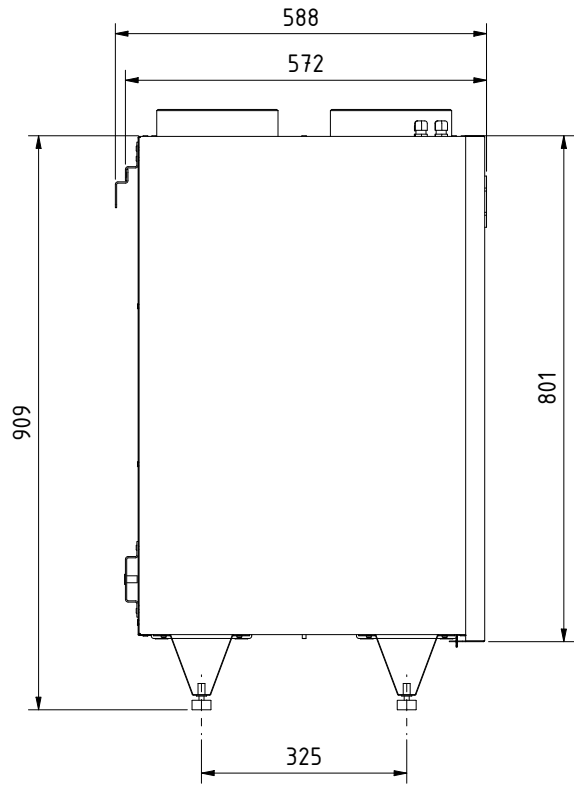
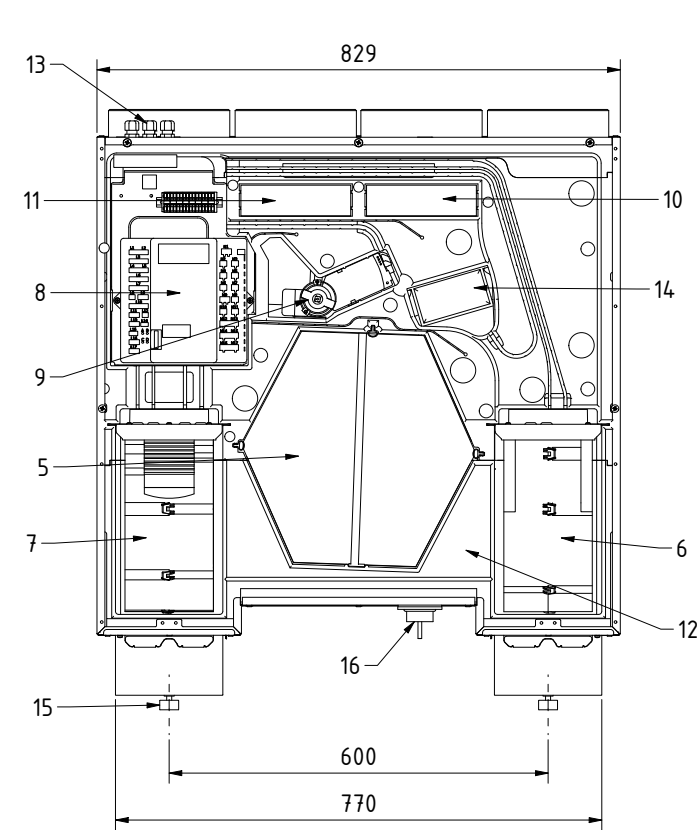

- 1 Supply air DN 160
- 2 Extract air DN 160
- 3 Outdoor air DN 160
- 4 Exhaust air DN 160
- 5 Counterflow heat exchanger
- 6 Exhaust air fan
- 7 Supply air fan
- 8 Controller
- 9 Bypass flap
- 10 Outdoor air filter
- 11 Extract air filter
- 12 Condensate tray
- 13 Cable feed-throughs
- 14 Electric pre-heater battery (optional)
- 15 Height-adjustable feet  
(Removable adjustable foot brackets)
- 16 Condensate outlet DN 40

Illustration: LG 350 & LG 450 (left-hand version)

SPECIALIST PERSONNEL



UNIT DESIGN

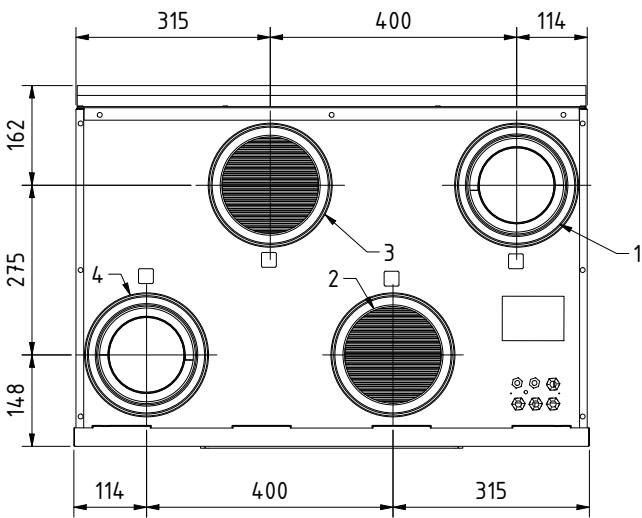
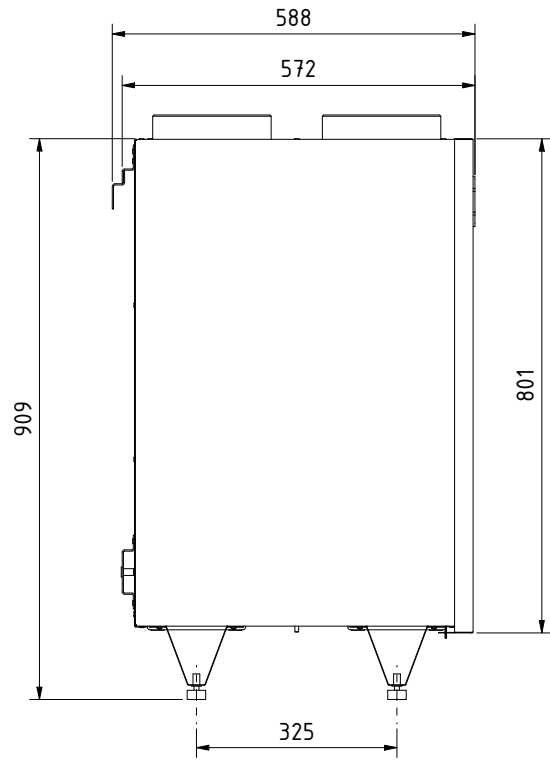
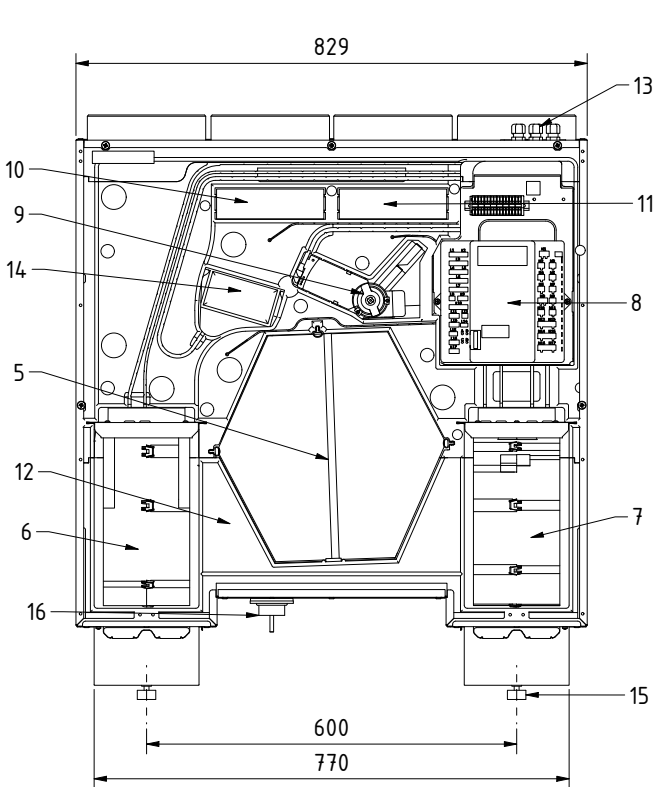

- 1 Supply air DN 160
- 2 Extract air DN 160
- 3 Outdoor air DN 160
- 4 Exhaust air DN 160
- 5 Counterflow heat exchanger
- 6 Exhaust air fan
- 7 Supply air fan
- 8 Controller
- 9 Bypass flap
- 10 Outdoor air filter
- 11 Extract air filter
- 12 Condensate tray
- 13 Cable feed-throughs
- 14 Electric pre-heater battery (optional)
- 15 Height-adjustable feet  
(Removable adjustable foot brackets)
- 16 Condensate outlet DN 40

Illustration: LG 350 & LG 450 (right-hand version)

GENERAL

USER

SPECIALIST PERSONNEL

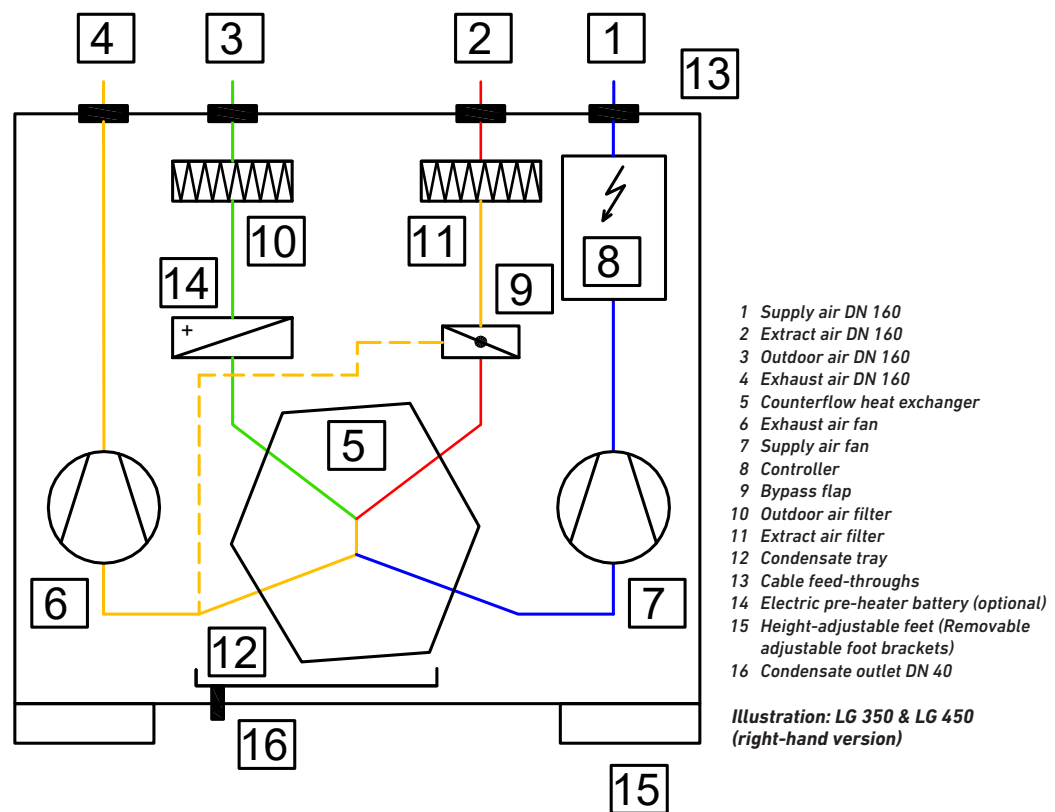

**1. Supply air inlet (SUP)**

Connecting piece for the supply air duct via which the processed, fresh air is conveyed into the rooms.

**2. Extract air outlet (ETA)**

Connecting piece for the extract air duct via which the used air is transported from the rooms.

**3. Outdoor air connector (ODA)**

Connecting piece for the outdoor air duct via which the unprocessed air flows into the unit from the outside.

**4. Exhaust air connector (EHA)**

Connecting piece for the exhaust air duct via which the used air flows from the unit to the outside.

**5. Counterflow heat exchanger (enthalpy exchanger)**

The efficient heat exchanger serves to transfer the heat from the warmer to the cooler air. Furthermore, enthalpy exchangers additionally provide for the transfer of humidity.

**6. Exhaust fan**

Provides for the required air volume flow in the extract or exhaust air.

**7. Supply fan**

Provides for the required air volume flow in the outdoor or supply air.

**8. Controller**

To the internally prewired controller, the control unit, a LAN cable, and, in addition, optional components such as external sensors, pumps, flaps, etc. can be connected. Furthermore, via a micro USB interface, the customer service can configure the operating parameters and possibly available optional components.

**9. Bypass flap with actuator**

Serves to bypass the heat exchanger, if necessary.

**10. Outdoor air filter**

Dust and impurities are filtered out of the outdoor air via the outdoor air filter.

**11. Extract filter**

Coarse contaminations are filtered out of the extract air via the extract air filter, in order to protect the inside of the device against pollution.

**12. Condensate tray**

Condensate which accumulates during operation in the heat exchanger is collected via the condensate tray.

**13. Cable feed-throughs**

The cable feed-throughs are used to establish electrical connections to connect the control unit with optional system accessories such as temperature sensors, etc.



**14. Electric pre-heater battery**

Serves to protect the condensate in the heat exchanger from freezing when outdoor temperatures get very cold. Via the optional electric pre-heater battery, the outdoor air is preheated, depending on the outdoor air and exhaust air temperature (see Section 14, "Safety devices").



If a water or brine battery is optionally used in order to protect the heat exchanger against frost, these components must be properly protected against freezing when there is frost.

**15. Height-adjustable feet**

Serve to align the ventilation unit horizontally in order to ensure reliable drainage of the condensate. In the case of wall mounting, the adjustable foot brackets can be easily removed.

**16. Condensate drainage**

Via the condensate drain connected, which is to be provided with an effective odour blocking trap (siphon), the accumulating condensate water is drained.

**SAFETY DEVICES**

To ensure safe operation of the system, safety devices and covers must never be rendered inoperative; nor may measures be taken to bypass or dismantle them.

Further use must be actively prevented until the unit is fully repaired.

The repair must only be carried out by a specialist company.

In the event of errors or any damage on the ventilation unit, which may cause harm to persons or property, the system must be put out of operation immediately and must be protected against restart.



## 15. System description and expansion options

### FROST PROTECTION OPTIONS



There is a risk of the heat exchanger freezing on the exhaust air side, particularly during winter months with moderate to severe frost, depending on the extract air temperature and air humidity. Appropriate measures must be taken to protect the

heat exchanger against ice formation at low outdoor air temperatures.

Various systems are available to monitor defrosting of the heat exchanger. Possible strategies to protect the heat exchanger against freezing are outlined below.

### Frost protection by reduction of the supply air volume flow



This operating mode is not suitable for frost protection in passive houses! This operating mode does not guarantee a balanced air flow volume between supply air and extract air during defrosting!

As a standard, the compact ventilation unit is provided with an automatic frost protection system for the heat exchanger.

#### *Frost protection via the extract air defrosting:*

- The defrosting mechanism is only activated at outdoor air entry temperatures of below  $-4\text{ }^{\circ}\text{C}$ .

- If the exhaust temperature falls below the "Defrost On" parameter, the defrosting process is started.
- Furthermore, the difference in temperature between extract air and supply air is monitored. The defrost process also starts when the "Defrost differential" parameter setting is exceeded.

#### *Defrost process:*

The supply air volume flow with a consistent extract air volume flow is continuously reduced and is finally switched off. After the defrost period has elapsed, the rotational speed on the supply air fan is increased continuously again.

### Electrical pre-heater battery



The LG 350 and LG 450 compact ventilation units are optionally available with an integrated, electrical pre-heater battery, by means of which the cold outdoor air is pre-heated if necessary.

#### *Frost protection via infinitely variable control of the pre-heater battery:*

- At an outdoor air intake temperature of below  $-4\text{ }^{\circ}\text{C}$ , the pre-heater battery is activated.
- With the infinitely variable setting and control of the pre-heater battery, the temperature is maintained above freezing and therefore prevents freezing of the heat exchanger.

- If the outdoor air intake temperature increases to over  $-3\text{ }^{\circ}\text{C}$ , the pre-heater battery is switched off again.
- If the ventilation unit with integrated pre-heater battery is switched off manually, a stopping time of the fans for cooling of the pre-heater battery is activated.



If the device is equipped with an enthalpy exchanger, the values specified above will deviate.

#### *Overheating protection*

In order to provide protection against overheating in the event of an error, the integrated pre-heater battery is equipped with an installed mechanical safety temperature limiter (STL). If a temperature of approx.  $+50\text{ }^{\circ}\text{C}$  is reached, the power supply to the electric battery is interrupted and the anti-freeze heating is switched off. The safety temperature limiter that is triggered is reset by pressing the white button on the pre-heater battery with a pointed object.



**Constant pressure control**

The compact ventilation unit can be optionally provided with a constant pressure control. For this purpose, the external dual pressure sensor set (08LGDRUCKDUALSET) is required.

A constant pressure control is for example used if volume flow controllers are installed.

The factory default for the ventilation unit is the "constant volume flow" fan control. In order to change the fan control to "constant pressure", a touch display (service login required) or the service software is necessary.

For more detailed information, please refer to the separate instructions.

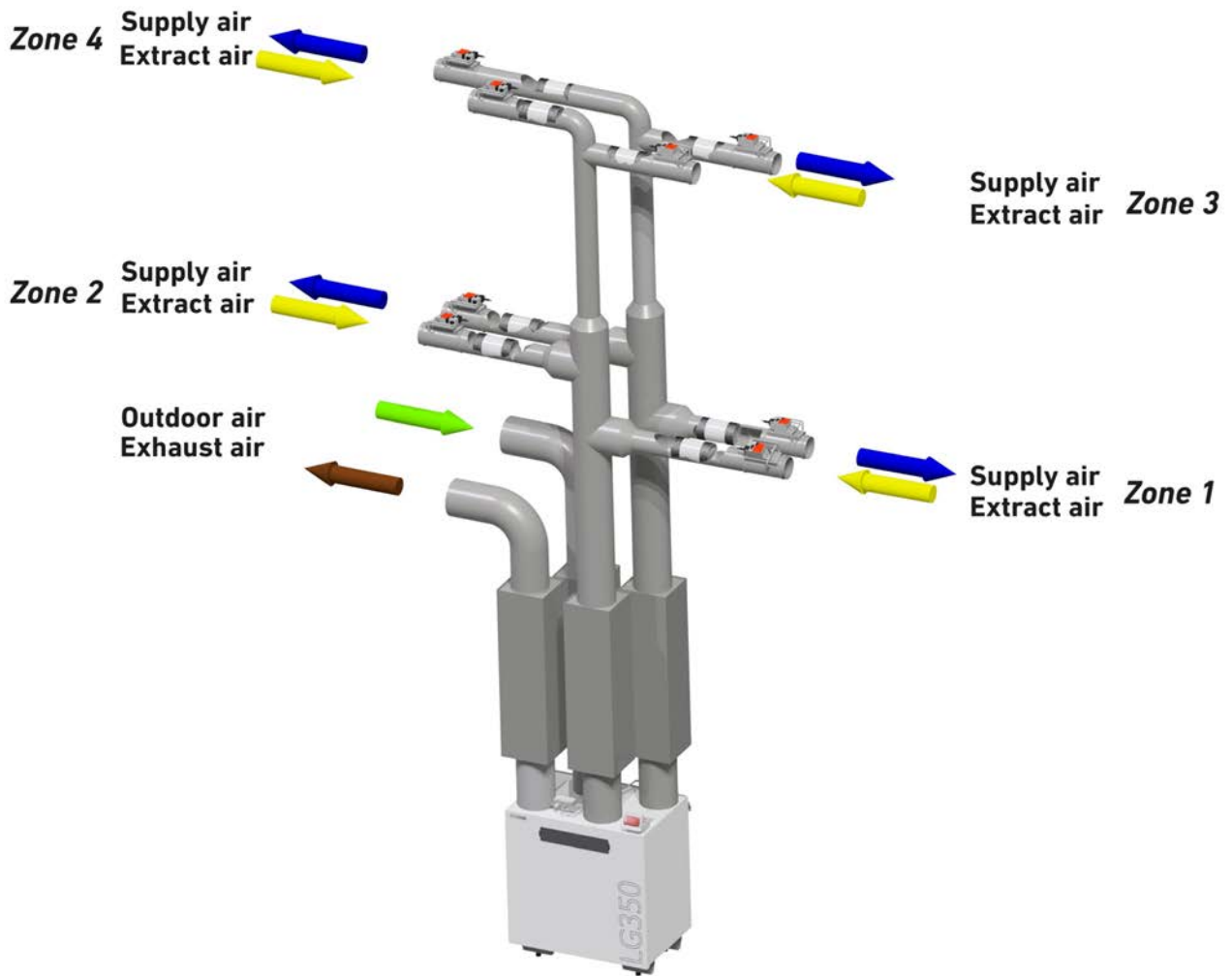

*Illustration: Example of a central system solution: compact ventilation unit with constant pressure control and volume flow controllers*



GENERAL

USER

**Geothermal heat exchanger**

Optimal frost protection can be achieved with cold outdoor air temperatures by integrating a geothermal heat exchanger (GHE) into the ventilation system.

*The following information must be observed for execution of a geothermal heat exchanger:*

- The heat exchanger is laid in the ground with waterproof pipes at a frost-free depth with due consideration of the system's cleanability options.
- The manufacturer's guidelines for implementation must be observed.
- Condensate drainage must be provided for.
- A sufficient descent for condensate drainage must be provided for.
- If the air pipe is routed through an external wall, effective sealing against moisture ingress must be ensured.
- Sufficient distance from other parts, e.g. water pipes, foundations, etc. must be maintained during positioning in order to prevent frost damage.
- The option of indirect pre-heating via a circulatory system with frost-protected heat carrier, for instance, should preferably be used in ground containing hazardous substances (e.g. radon contamination).



To ensure energy efficiency and air hygiene, geothermal heat exchangers must be carefully planned and implemented. The relevant

guidelines and standards must be observed. In particular, among other things, ease of cleaning and a suitable filter concept must be ensured.

The use of a geothermal heat exchanger with a changeover flap must be specifically activated in the ventilation unit. PC software is used for this purpose.

**Geothermal heat exchanger (GHE) winter mode**

The geothermal heat exchanger is connected via the changeover flap when the outdoor temperature (optional outdoor temperature sensor required) falls below the geothermal heat exchanger's parameterised winter threshold value. In this case, the outdoor air is drawn in via the geothermal heat exchanger and is therefore pre-heated.

**Geothermal heat exchanger summer mode**

In summer, the geothermal heat exchanger is connected when the outdoor temperature (optional outdoor temperature sensor required) exceeds the geothermal heat exchanger's parameterised summer threshold value. In this case, the outdoor air is drawn in via the geothermal heat exchanger and is thus pre-cooled.



The impact of the geothermal heat exchanger significantly depends on the local conditions, the operating mode and the dimensioning of the device.

SPECIALIST PERSONNEL

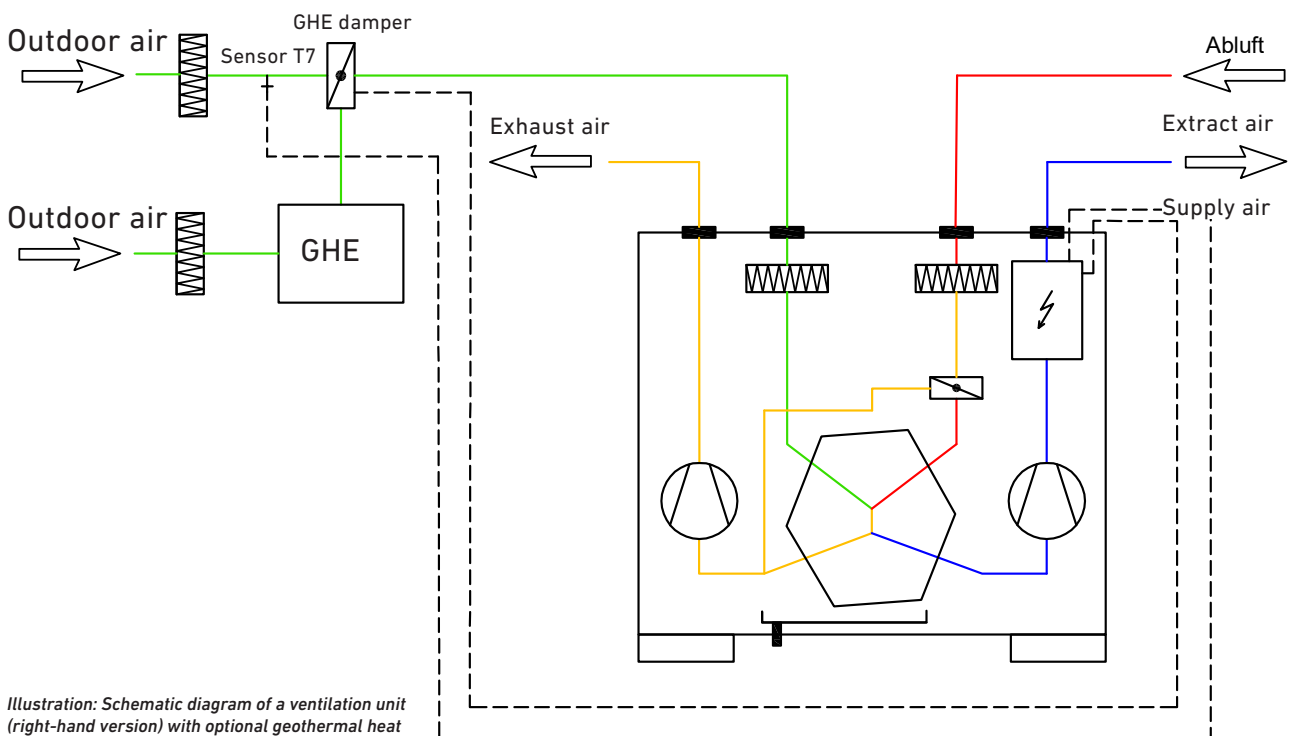

Illustration: Schematic diagram of a ventilation unit (right-hand version) with optional geothermal heat exchanger



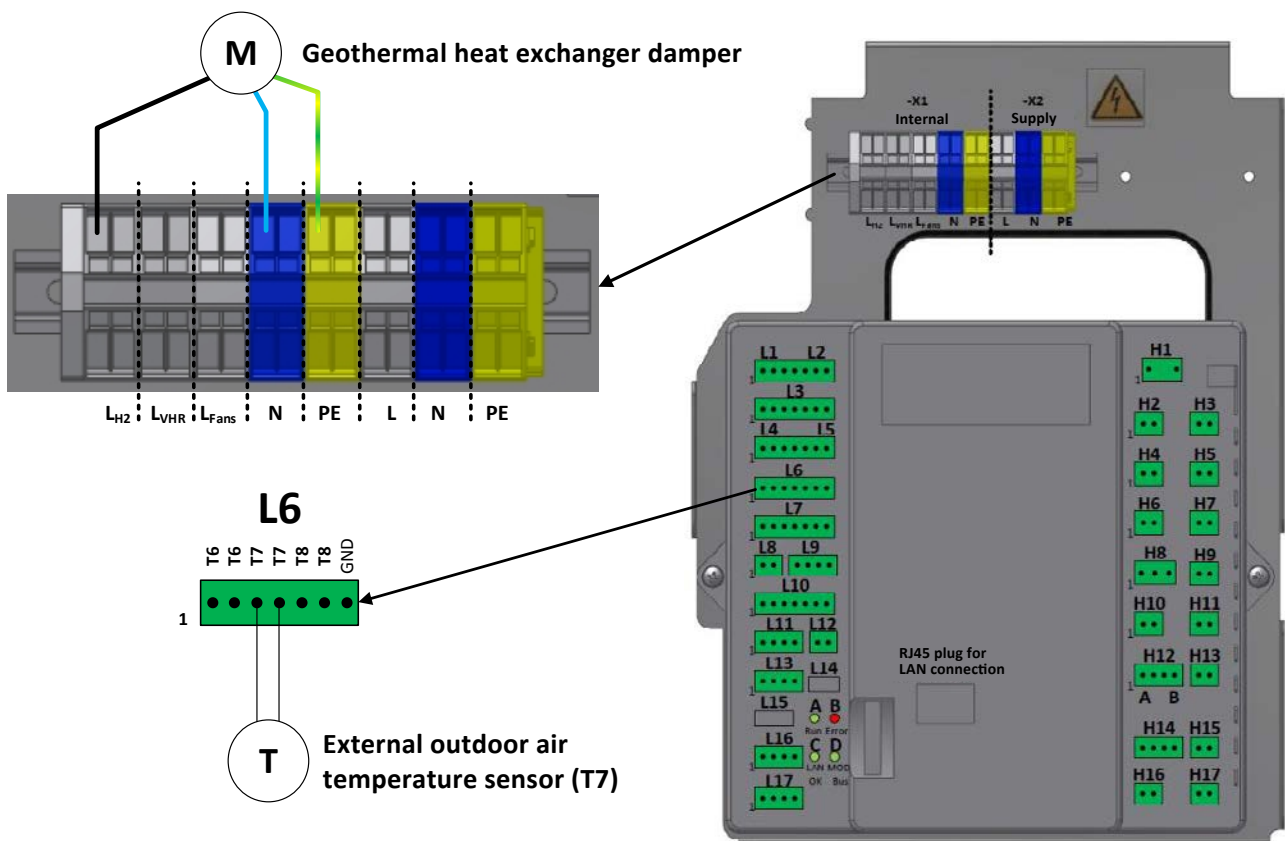

Illustration: Terminal assignment for the geothermal heat exchanger flap

**Brine geothermal heat exchanger**

Brine geothermal systems extract energy from the earth in winter via a brine pipe. The system may also be used for cooling in summer. The heat or cold is transferred indirectly to the outdoor air via an external air register in the air duct system.

Compared to other frost protection mechanisms such as electrical pre-heater batteries, brine geothermal systems provide the benefit of requiring only little energy for operation. Their advantages compared to the geothermal heat exchanger are for instance hygienic aspects, simple laying and good controllability.



Indirect pre-heating via a circulatory system with frost-protected heat carrier, for instance, should preferably be used in ground containing hazardous substances (e.g. radon contamination).

The manufacturer's guidelines for implementation must be observed. The brine heater battery must be protected against

contamination by an external coarse dust filter integrated into the air pipe system. The brine pump is activated automatically, depending on the outdoor air temperature.

Support of a brine geothermal heat system must be activated by means of the PC tool in the controller of the ventilation unit. PC software is used for this purpose.

**Brine geothermal heat – winter mode**

If the outdoor temperature (optional outdoor temperature sensor required) falls below the geothermal heat exchanger's winter parameter, a relay switches on the brine pump.

**Brine geothermal heat – summer mode**

If the outdoor air temperature (optional outdoor air sensor required) exceeds the geothermal heat exchanger's summer parameter, a relay switches on the brine pump.



GENERAL

USER

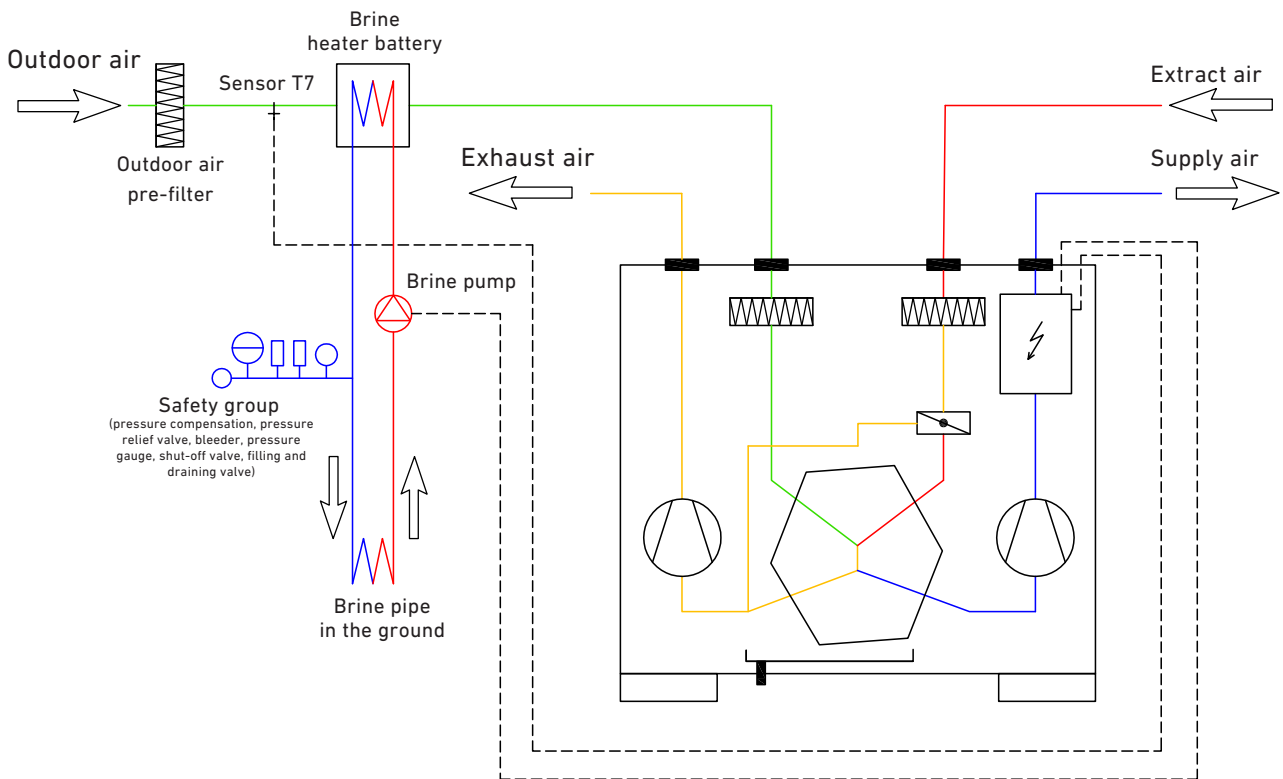

Illustration: Schematic diagram of a ventilation unit (right-hand version) with optional brine geothermal heat exchanger

SPECIALIST PERSONNEL

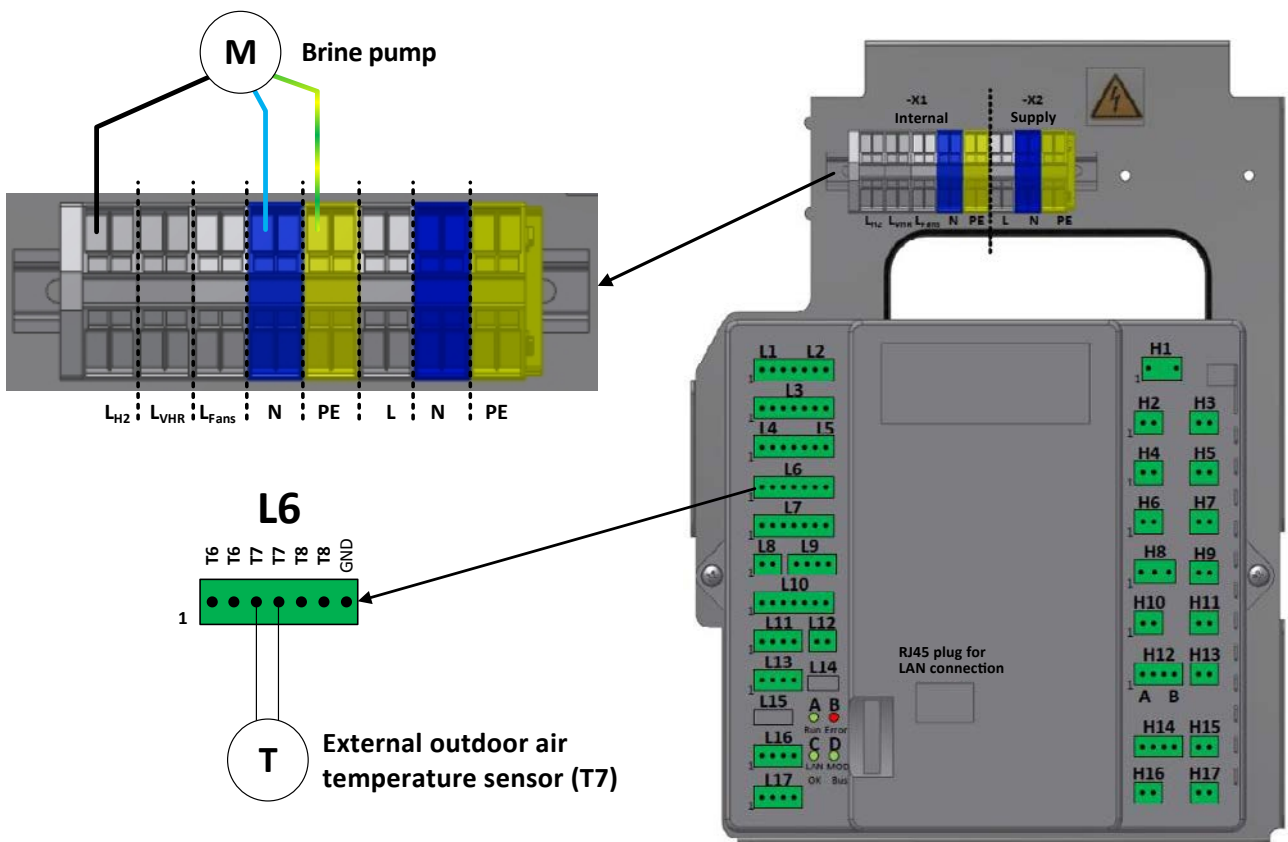

Illustration: Terminal assignment for brine geothermal heat exchanger



**SYSTEM EXTENSION FOR EXTERNAL SUPPLY AIR CONDITIONING**

In order to increase or reduce the supply air temperature for the room, an external heater, cooling or combination battery can be activated by means of the ventilation unit controller.

These devices are configured by PC software. The setpoint selection for the temperature and recording of the room temperature are effected via the TOUCH control unit (see Section 9, "Settings" and Section 23, "Spare parts and accessories").

**External electric re-heating battery**

Via an external, infinitely variable electric heater battery which is connected downstream in the supply air of the ventilation unit, the supply air temperature (T6) can be increased.

In order to control the electric re-heating battery, an additional temperature sensor must be connected downstream to the battery. If no temperature sensor is connected, an error message is output.

If the electric re-heating battery is active, the fan will continue running for 120 seconds when the unit is switched off.

 The "Additional heating" operating mode is only active in winter operation!

 Operation of the external electric re-heating battery requires a separate voltage supply. The heater battery is controlled via an external 230 V contactor and a 0-10 V signal.

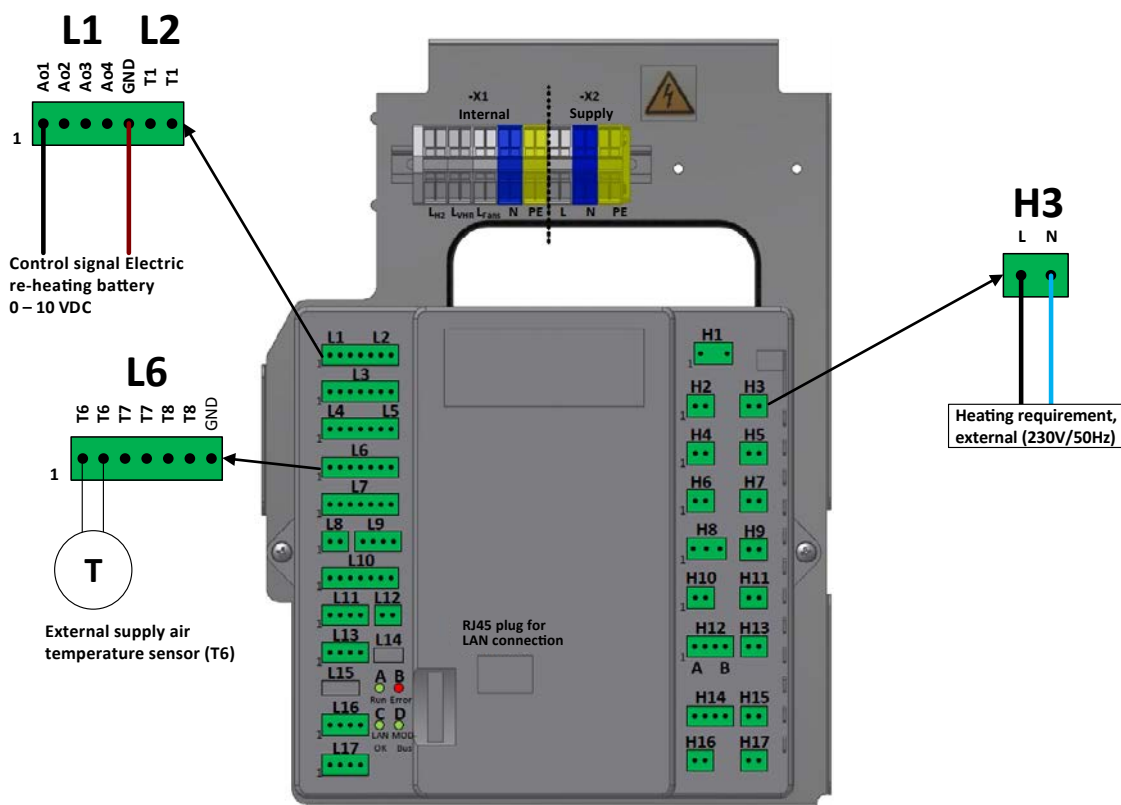

Illustration: Terminal assignment for an external electric re-heating battery

GENERAL

USER

SPECIALIST PERSONNEL



GENERAL

USER

**External warm water re-heating battery**

Via an external water re-heating battery which is connected downstream in the supply air of the ventilation unit, the supply air temperature can be increased.

Mixing operation of the 3-way water valve is continuously controlled via a 0-10 V signal. The external supply air temperature sensor must be installed downstream to the warm water heater battery and connected to the closed-loop control (T6). If no temperature sensor is connected, an error message is output.

**Frost protection**

If the warm water re-heating battery is configured in the controller, the input (Di3) can be used as contact. This contact is used for the purpose of frost protection of the re-heating battery.

If the contact is opened via an external frost protection thermostat, the ventilation unit switches to frost protection and reports an error. The frost protection thermostat is to be positioned on the return pipe of the warm water re-heating battery.

In this error status, the mixer is opened and the circulating pump is activated. The fans are switched off until the frost hazard warning is cancelled again.

Additionally, the same frost protection mechanism is applied when the temperature on the integrated supply air sensor drops below +5 °C.

 The "Additional heating" operating mode is only active in winter operation!

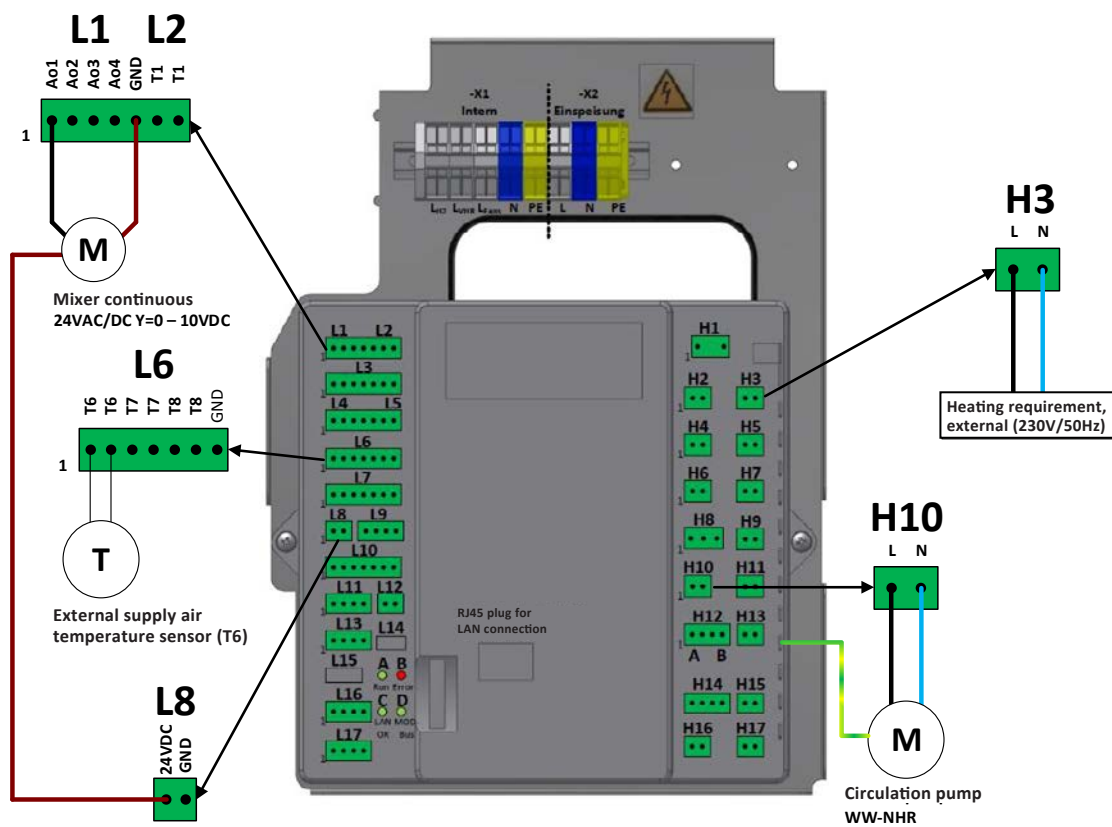

Illustration: Terminal assignment for an external warm water re-heating battery

SPECIALIST PERSONNEL



**External cold water cooling battery**

Via an external cold water cooling battery which is connected downstream in the supply air of the ventilation unit, the supply air temperature can be cooled.

Mixing operation of the 3-way water valve is continuously controlled via a 0-10 V signal. The external supply air temperature sensor must be installed downstream to the cold water battery and connected to the closed-loop control (T6). If no temperature sensor is connected, an error message is output.

☞ The "Cooling" operating mode is only active in the summer mode and is activated when the temperature is 2 Kelvin above the setpoint of normal operation!

☞ In cooling operation, a large amount of condensate may accumulate, which must be drained via a condensate drain to be installed on site.

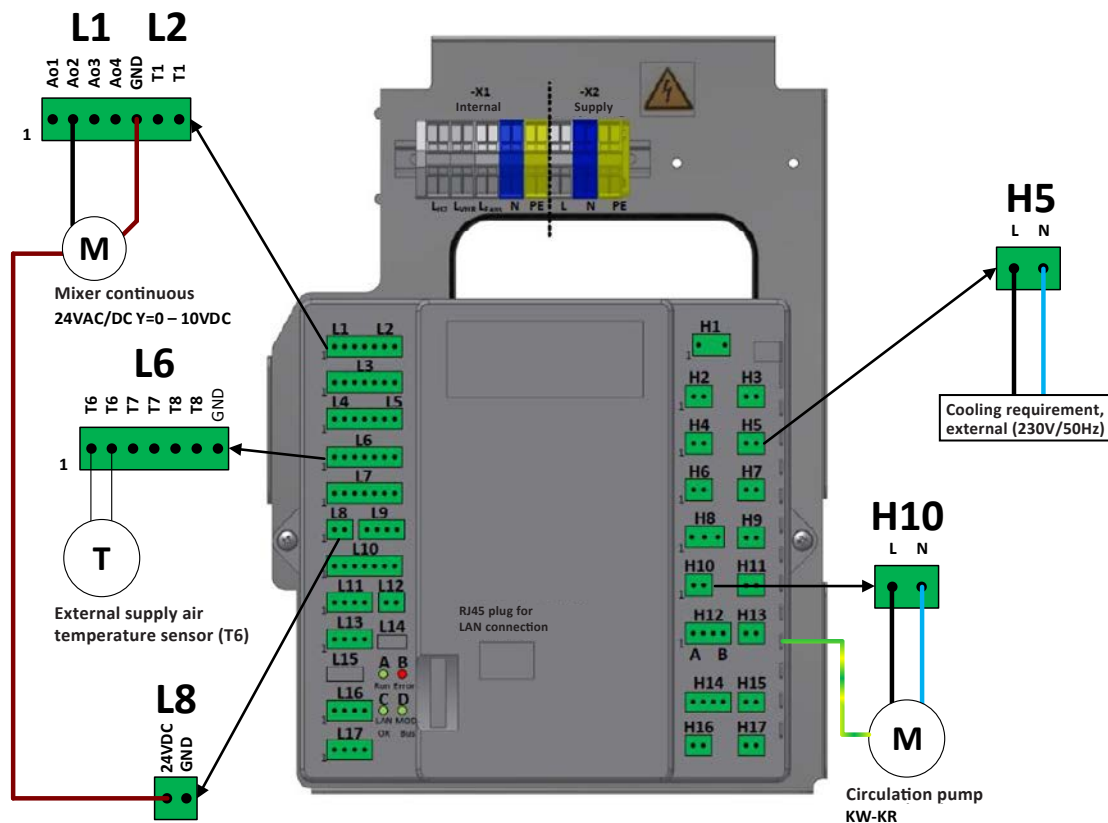

Illustration: Terminal assignment for an external cold water cooling battery

GENERAL

USER

SPECIALIST PERSONNEL



GENERAL

USER

**External combination battery (warm or cold water)**

The external combination battery combines the functions of a warm water re-heating battery and a cold water cooling battery in one component. For the

external warm or cold water requirement, the 230 V switching outputs H3 and H5 can be used.

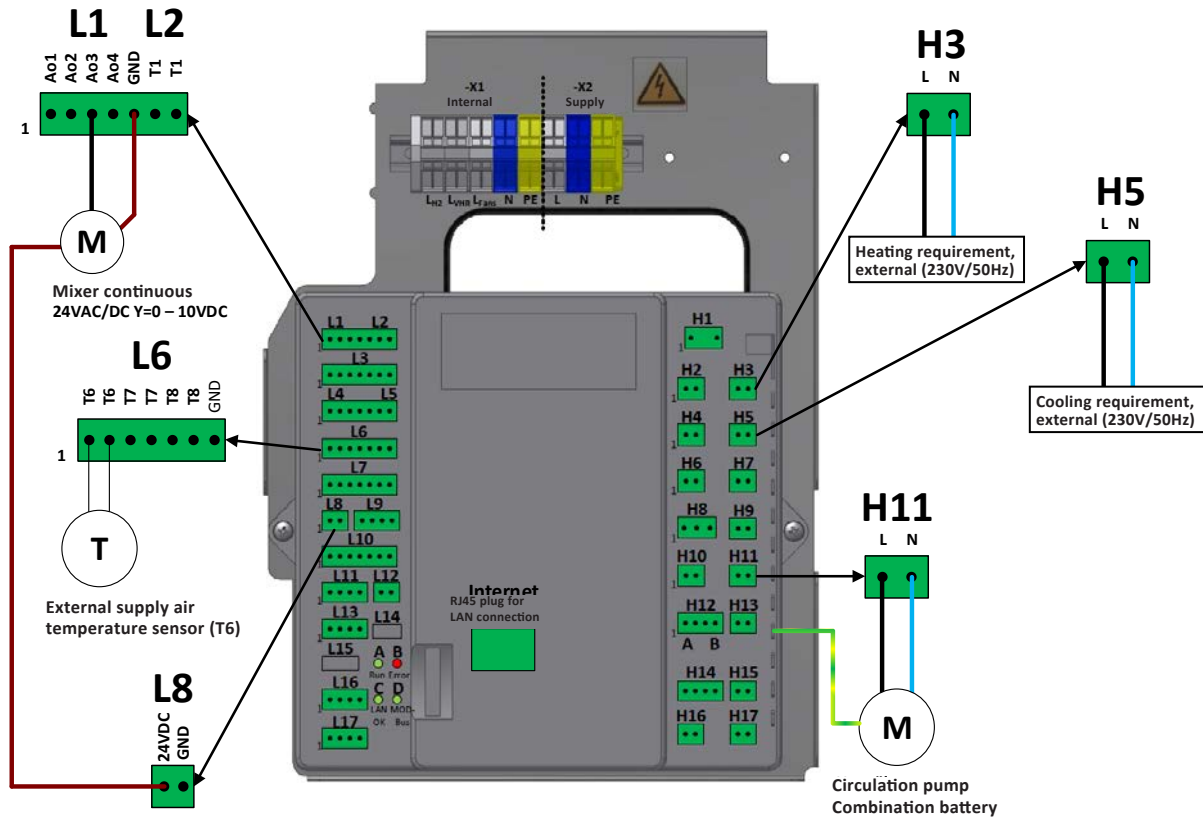

Illustration: Terminal assignment for an external combination battery (warm or cold water)

SPECIALIST PERSONNEL

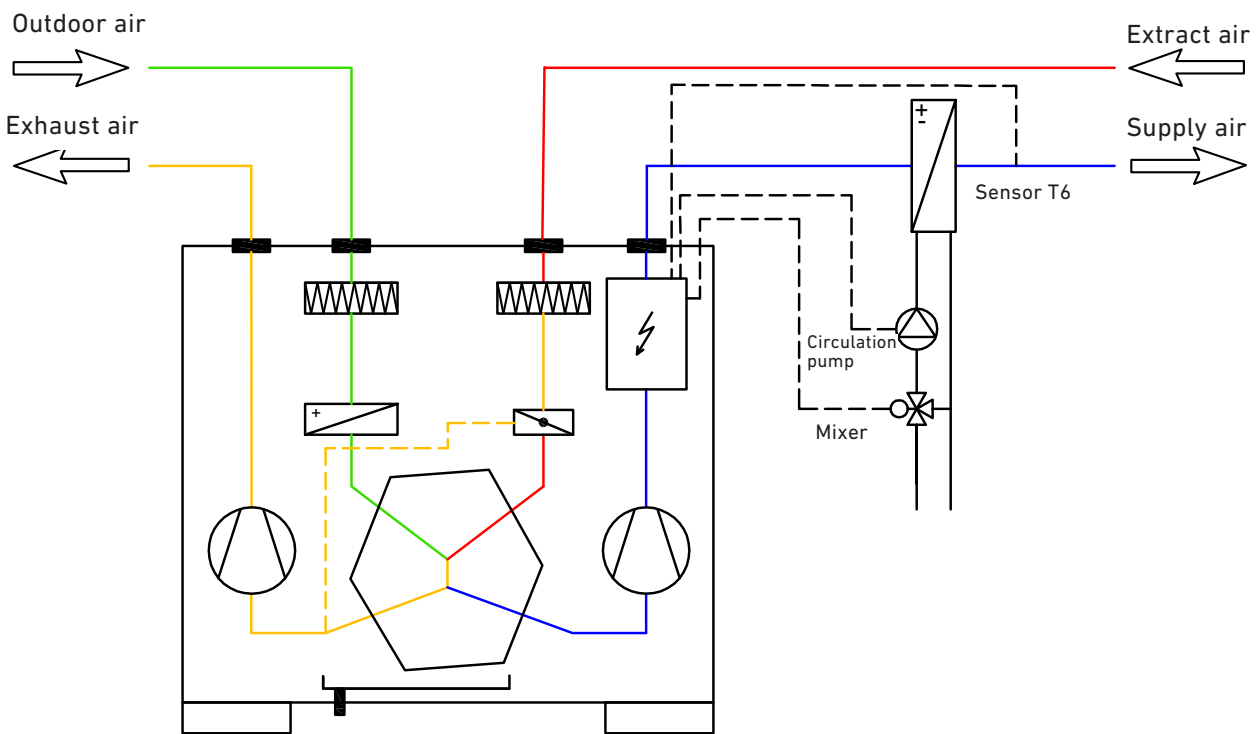

Illustration: Schematic diagram of a ventilation unit (right-hand version) with an optional warm water re-heating, cold water cooling or combination battery



## 16. TOUCH control unit service level

The service menu is activated by pressing the [Menu] button for an extended period (min. 5 seconds) and entering the password.



The service menu is shown by an "S" in the top left corner of the screen. When the service menu has been activated, the technician can change system parameters.



### Information/Current operating values

All of the unit's parameters can be checked in the Main menu > [Information] > [Current operating values].

### Actions

[Menu] > [Actions] is extended by the following menu items:

- Reset time meter
- Delete message overview
- Test mode: To test the basic functions of the unit



- Update the unit's firmware



## TOUCH CONTROL UNIT TEST MODE

### Activate test mode

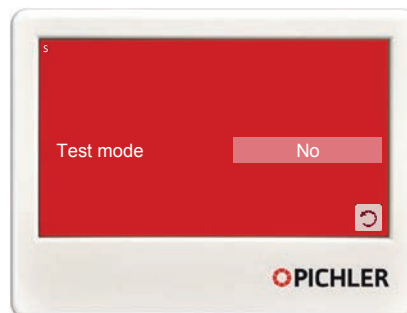

Here, the test mode can be activated with [Yes] and deactivated with [No]. Relays H2, H3, H5, H67, H9, H10, H11, H12A and H12B are used to control the individual outputs

### Test – bypass flap

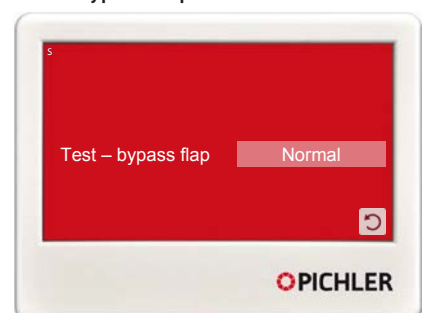

With the "Test – bypass flap" function, the bypass flap can be manually traversed to the heat recovery or bypass position. With [Normal], the flap position is controlled automatically.



**Test – fan supply air**

In order to manually test the supply air fan, the test mode must be activated with [Yes] first. Then the volume flow can be manually defined under "Test – supply air fan". In order to exit the test mode, the test mode must be deactivated with [No].

**Test – fan exhaust air**

In order to manually test the supply air fan, the test mode must be activated with [Yes] first. Then the volume flow can be manually defined under "Test – exhaust air fan". In order to exit the test mode, the test mode must be deactivated with [No].

## 17. Mounting

### PREREQUISITES FOR INSTALLATION OF THE UNIT

The LG 350 and LG 450 ventilation units must be installed in accordance with the general and locally applicable safety and installation regulations and to the specifications in this manual. Mounting and installation work may be performed by authorised specialist personnel only.

The ventilation unit may only be installed in a frost-free room, e.g. in a cellar or loft, with ambient temperatures ranging between +5 °C and +35 °C. Accumulating condensate must be discharged, frost-free and safely, via a gradient and using effective siphoning to block odours. The unit's installation position must allow sufficient space for air ducts, electrical connections, condensate drain connection and maintenance and inspection.

Leave at least 1 m free space in front of the unit to allow for operation and servicing.

The ventilation unit must be set up on an even and sufficiently firm installation surface. The ventilation unit can also be mounted to a solid wall using the wall mounting bracket included in the scope of supply. In doing this, adequately suitable dimensioning (statics) of the load-bearing components must be observed.

The following connection facilities must be available in the installation area:

- Air duct connections for supply, extract, outdoor and exhaust air

- Electrical mains connection 230 V / 50 Hz, 16 A fuse
- Condensate drain pipe with an effective odour blocking trap (siphon)

All on-site work (drainage, floor structure etc.) must be completed before installing the ventilation unit. The ventilation unit will be firmly in position once the air ducts have been connected and cannot be moved.

The outdoor air and exhaust air ducts, e.g. between the ventilation unit and the roof feed-through, must be sufficiently heat-insulated for energy reasons and to prevent condensate formation. Condensate must not be allowed to form on the air ducts and roofing. Any lines running outside the thermally insulated building shell must be adequately insulated in cold areas.

To ensure proper and functional operation of the unit, suitable thermal and sound insulation and installation materials must be provided as per the planning documentation and technical data, such as sound absorbers of adequate size, supply air and extract air valves, overflow openings etc. All equipment connectors should in principle be fitted with sound absorbers to ensure appropriate acoustic damping in the room.

Air duct feed-throughs through walls or ceilings must be isolated against structural vibrations.



To protect the unit from coarse soiling such as foliage, leaves or insects, a fine wire mesh grating must be provided as a pre-filter directly at the central inlet point for outdoor air. The protective grating must be checked and cleaned at regular intervals, if necessary, especially in spring and autumn.

If necessary, inspection openings should be provided in the air duct system to facilitate cleaning and maintenance of the unit.

## OPENING THE UNIT

To open the unit, proceed as follows:

1. Remove the filter cover by pressing the two latches positioned on the outside towards the inside.
2. Lift the device front until the top securing brackets are fully extracted from the device cover and then pull the device front towards the front again.
3. Set the device front aside carefully and make sure that it is standing securely.

Before opening the unit and when carrying out work on the unit, e.g. maintenance work and repairs, etc., the unit must be de-energised (disconnection of the voltage supply for all poles) and must be protected against restart for the duration of the work performed.



4. Loosen the five screw fittings of the seal front using a Philipps screwdriver and remove it.

5. In order to close the unit, proceed in reverse order and make sure that the seat of the seal front is tight.

## UNIT INSTALLATION



For all work steps, the safety instructions specified in **Section 5 "Safety"** must be observed!

### Free standing

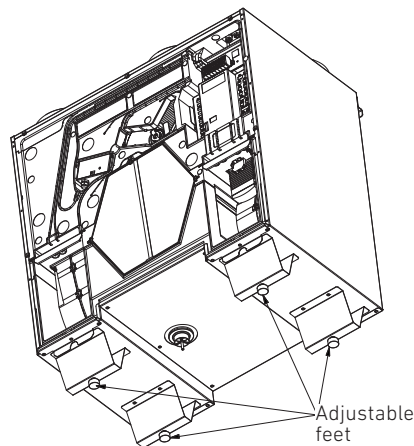

able feet supplied must first be mounted to the bottom side of the unit. For mounting the feet, the unit must be slightly tilted.

Screw on the feet tightly first. The unit is horizontally aligned by unscrewing the feet step by step. For this purpose, use a level.



The ventilation unit must be installed horizontal and secure. Optimum condensate drainage is only ensured when the unit is aligned exactly. The unit can be easily aligned via the adjustable feet.

After placing the unit in its position, it must be aligned.

In order to do this, the four height-adjust-

The unit design allows for the connection of a standard ball siphon at the condensate drain.



**Wall mounting**

If the ventilation unit is mounted on the wall, two of the feet included in the scope of supply must be mounted to the rear side of the unit. Fully screw the feet in first.

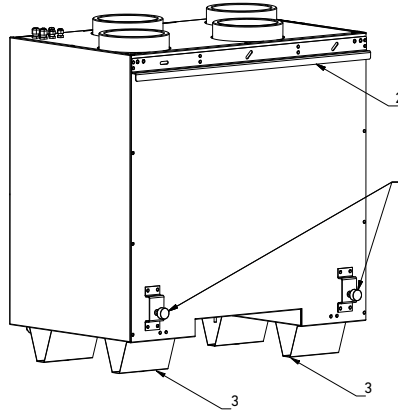

1 Adjustable feet  
2 Mounting rail  
3 Removable adjustable foot brackets

The wall mounting bracket included in the scope of supply is mounted horizontally to a suitable, solid and load-bearing wall. For this purpose, use a level.

After installing the wall mounting bar, the ventilation unit is mounted into the wall mounting bracket by means of the rail fixed to the rear side of the unit. By means of the feet previously screwed into the bottom side of the back panel, the unit is aligned vertically. In the case of wall mounting, the adjustable foot brackets can be easily removed



Optimum condensate drainage is only ensured when the unit is aligned exactly. The unit is aligned via the wall mounting bracket and the adjustable feet on the rear side of the unit.

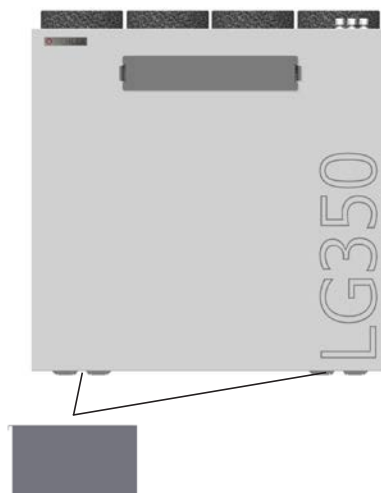

Removable adjustable foot brackets (4 x)



**ESTABLISHING THE CONDENSATE DRAIN CONNECTION**

In order to establish the condensate drain, first the unit front must be opened (see Section 17, "Opening the unit").

The drain pipe for the condensate preferably has to be designed using rigid piping, reliable drainage of the water requiring the provision of a sufficient descent. Otherwise, the accumulating condensate cannot be drained from the unit properly, which may cause water damage.

For establishing a proper connection, we recommend using a condensate siphon of the HL136.3 type for the unit.

In order to prevent the potential dispersion of odour as well as leakages, the siphons must always be filled with water.



Perfect functioning of the condensate drainage must be checked and ensured before putting the compact ventilation unit into operation. For this purpose, fill the condensate tray with a sufficient amount of water and check its outlet and the tightness of all connections and joints.



To ensure that the outlet is air-tight and condensate water-tight, adequate and reliable sealing to the unit housing must be observed when the seal front is closed.



Attention is drawn to the fact that a ball/dry siphon must be connected to the condensate connection, which drains into a free outlet, e.g. funnel siphon.

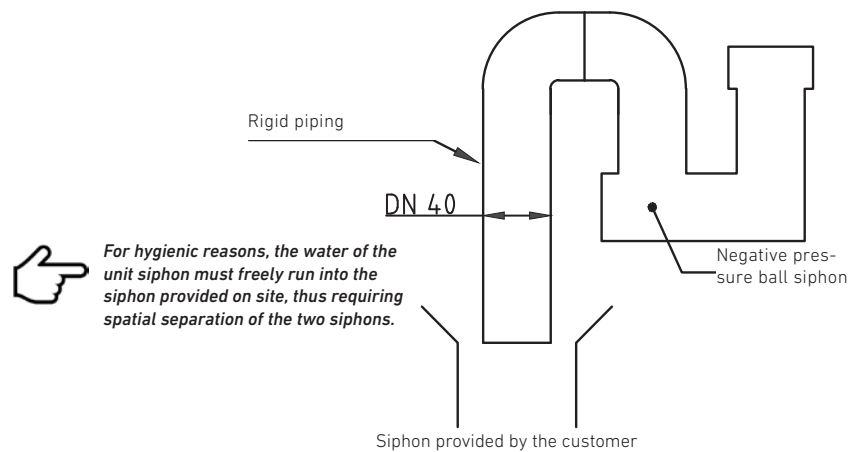
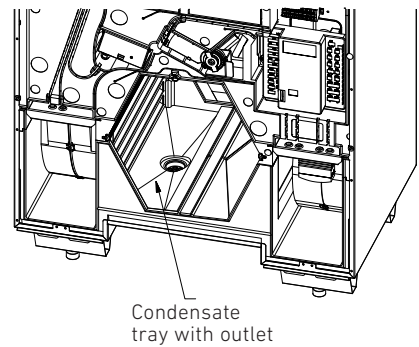
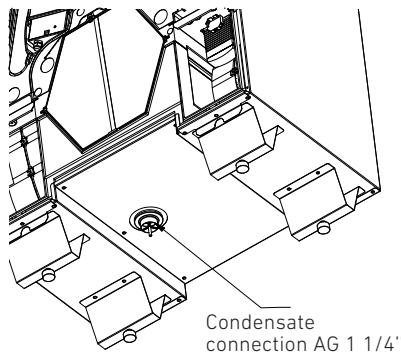

GENERAL

USER

SPECIALIST PERSONNEL



**CONNECTING AIR DUCTS AND COMPONENTS**

The air ducts Ø 160 mm must be connected to the connecting pieces at the top. Sufficient air-tightness must be observed.

The transitions can either be designed using EPP sleeves Ø 160 mm or using nipples with a double lip seal (system safe).

Air pipes and attachments such as sound absorbers etc. may only be attached to the ventilation unit using adequately dimensioned elements for mounting to

suitable solid wall or ceiling structural components. Avoid using flexible hoses for connections to the unit.



When making connections, ensure in particular that no tools or assembly material will fall into the connections to the unit or onto the unit itself. This could cause damage to components, for instance to the fans. Air duct and installation components must be suitably and adequately insulated in accordance with project specifications.

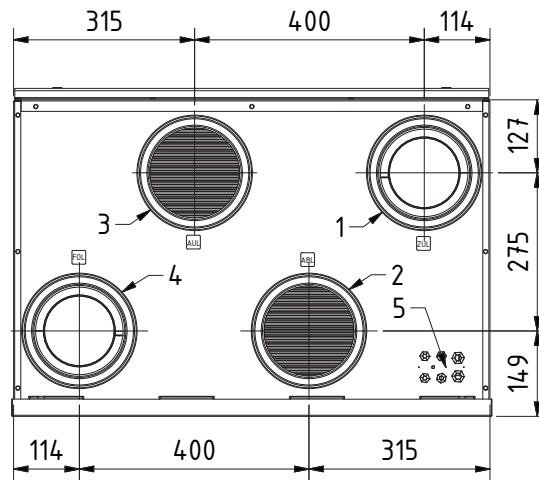

- 1. Supply air inlet ø 160 mm
- 2. Extract air outlet ø 160 mm
- 3. Outdoor air connector ø 160 mm
- 4. Exhaust air connector ø 160 mm
- 5. Cable feed-throughs  
2 x M12 / 4 x M16

**Illustration: LG 350 & LG 450 (right-hand version)**

**LEGEND FOR AIR TYPES**

The corresponding air type for each connection piece on the ventilation unit is marked by means of a symbol.



**Extract air**



**Outdoor air**



**Exhaust air**



**Supply air**



## 18. Electrical connection



The safety instructions specified in *Section 5, "Electrical connection work"*, must be observed when performing any electrical work.



Electrical connection work and work on electrical components may only be carried out by authorised electricians.

The relevant national and local regulations and standards must be complied with during assembly and electrical installation.

The compact ventilation unit of the LG 350 and LG 450 series is designed for a voltage supply of 230 V / 50 Hz.

- Electricians must be connected in accordance with the associated connection diagram (*see "Electrical connection diagram" in this section!*)
- The cable cross-sections indicated are minimum cross-sections for copper lines and do not take cable length or site conditions into account.

- Cable type, cable cross-section and laying must be determined by an authorised electrician.
- Low-voltage cables must be laid separately from mains cables; alternatively, screened cables must be used.
- The line fuse of the supply pipe must feature isolating characteristics.
- A separate cable inlet must be used for each cable.
- Unused cable inlets must be hermetically sealed.
- All cable entries must be strain-relieved.
- Potential equalisation must be put in place between the unit and the air duct system.
- All safety measures must be tested following electrical connection (earth resistance etc.).
- In order to prevent unsuitable residual current protective devices from being triggered, we strongly recommend the use of pulse and/or AC/DC sensitive residual current protective devices (type A or B) with delayed trip.

### OPENING THE UNIT

See *Section 17, "Opening the unit"*.

### CONTROL PCB

The control PCB is located in the top right half of the unit.



Before working on the control board, the unit must be isolated from the mains (all poles) and

protected from being switched back on. After opening the unit front and seal front, the terminals for the control lines and the electrical input fuse are accessible.



**MAINS CONNECTION AND REPLACEMENT OF THE INTERNAL DEVICE FUSING**

The ventilation unit is supplied ready to be plugged in. The mains power cable is approx. 3 m long and provided with a safety plug. The mains must be connected properly on site using a suitable earth contact plug and socket-outlet.



The earth contact plug and socket-outlet in the power connection ensures that all poles of the unit can be disconnected from the power supply.



The ventilation unit must only be operated with the rated voltage of 230 V / 50 Hz indicated on the nameplate. The line fuse of the supply line should have max. 16 A and feature isolating characteristics.

The supply line must be dimensioned by an authorised electrician in full compliance with the relevant guidelines.

In order to prevent unsuitable residual current protective devices from being triggered, we strongly recommend the use of pulse and/or AC/DC sensitive residual current protective devices (type A or B) with delayed trip.



Before working on the unit controller, the unit must be isolated from the mains (all poles) and protected from being switched back on. When the seal front has been unscrewed, the mains connection and the electrical fuses are accessible.

**Internal fuse:**

Ceramic fuses on the control board  
2 items T500mA H  $\varnothing$  5 x 20 mm  
1 item T5A H  $\varnothing$  5 x 20 mm

To replace the fuses, all connectors and the PE-wire must be disconnected from the earth rail first. Then the plastic housing of the controller can be removed carefully, and the fuses can be checked and replaced, if necessary.

**Cable feed-throughs**

Connection cables must be fed through the cable feed-throughs on the top of the ventilation unit in order to connect the cables for the relevant control unit as well as optional system components such as external reheating or external sensors.

All lines for external components such as sensors, actuators, pumps etc. must be connected in accordance with the wiring plan, *see the "Electrical connection diagram"* item in this section.

Lines must be dimensioned by an electrician. Low-voltage cables must be laid separately from mains cables; alternatively, screened cables must be used.

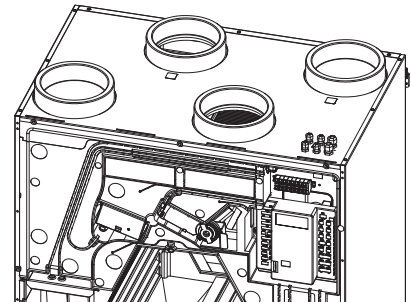
**ELECTRICAL CONNECTION DIAGRAM**

In general, external system components, extension components, and temperature sensors required must be connected in accordance

with the electrical connection diagram. The controller automatically recognises the electrical connection of outdoor temperature sensor T7.



sensor configuration == 0 (CO2 + rF):  
Ai1 = CO2; Ai2 = rF

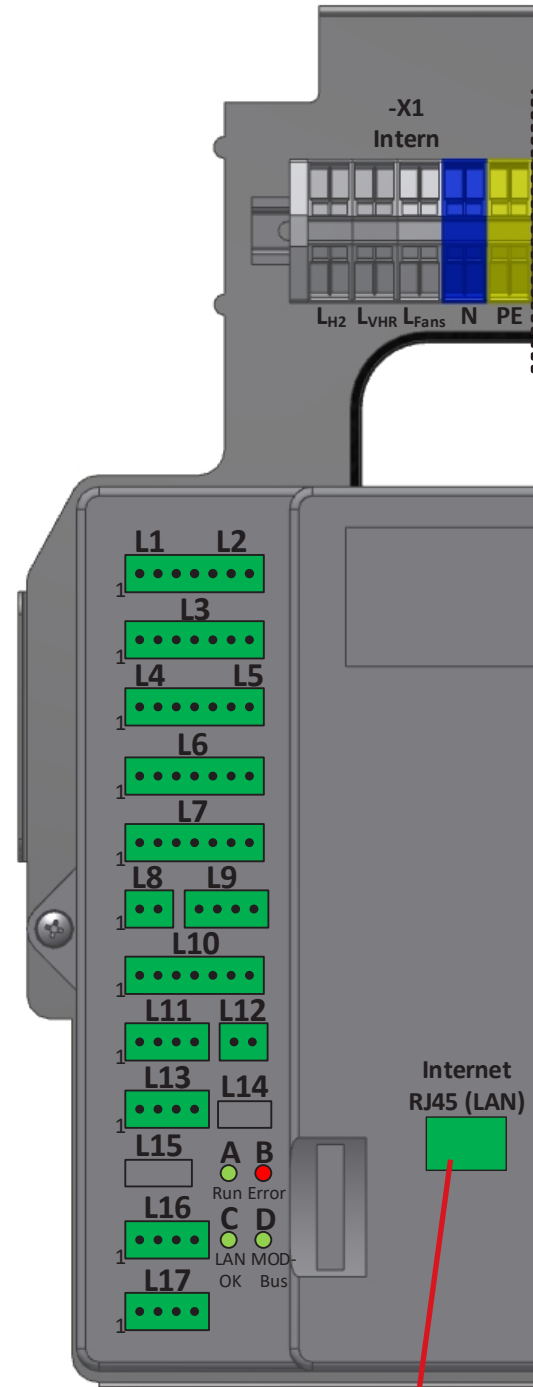
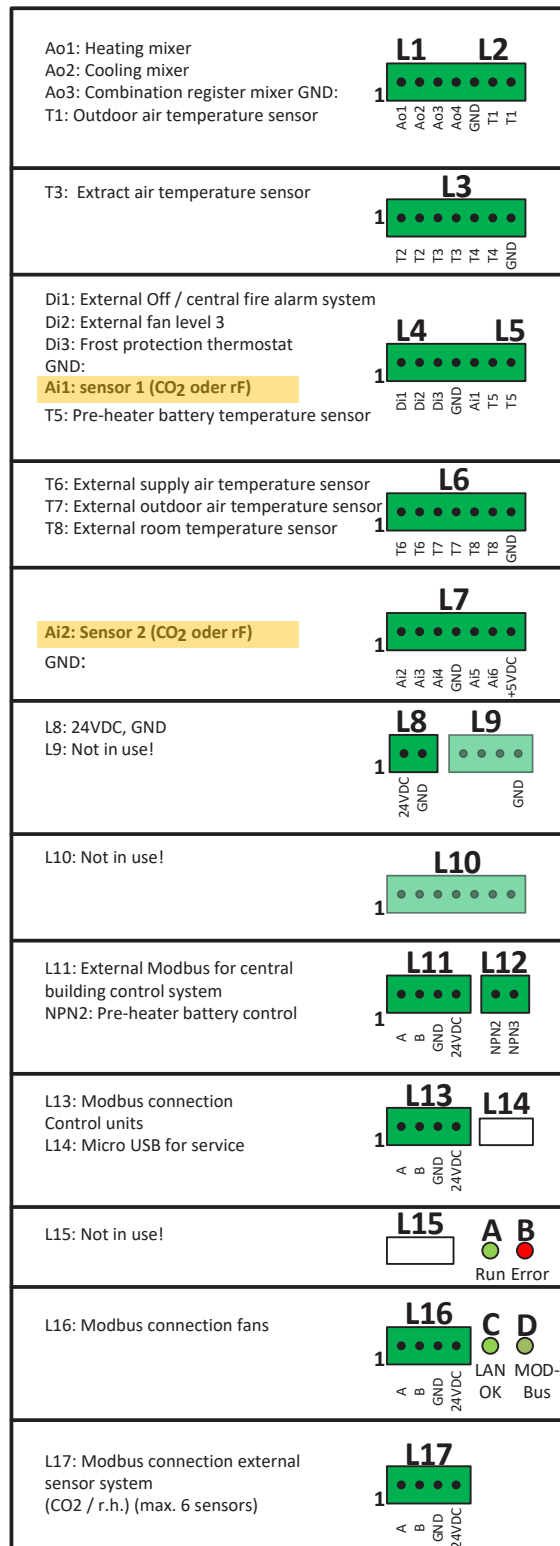

www.pichlerluft.at/  
datenschutz.html

www.pichlerluft.at/  
data-privacy-statement.html

A sticker is attached on the cover of the device. As soon as you establish a cable-controlled Internet connection, we assume your agreement to the current data protection statement. (see: <http://www.pichlerluft.at/data-privacy-statement.html>)



## 230V / 50 Hz

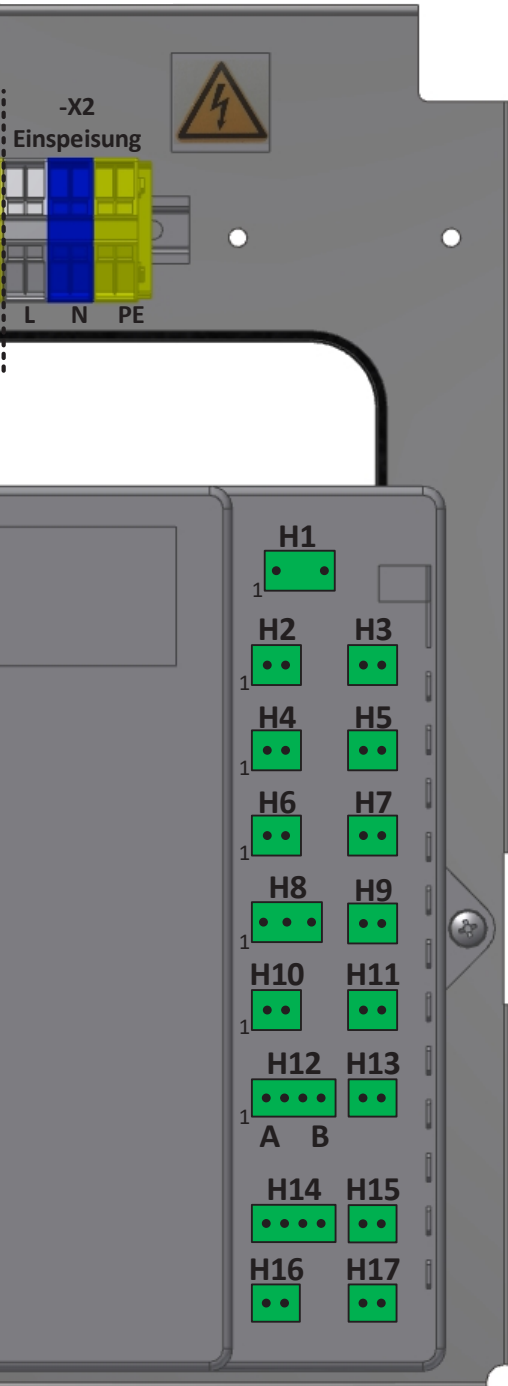

	<p><b>H1</b> H1: Supply Max. on-site line fuse = 16 A</p>
	<p><b>H2</b>   <b>H3</b> H2: Pre-heater battery / brine pump / geothermal heat exchanger damper H3: Heating requirement combination battery</p>
	<p><b>H4</b>   <b>H5</b> H4: Bridged contact! H5: Cooling requirement combination battery</p>
	<p><b>H6</b>   <b>H7</b> H6: Not in use! H7: Fans</p>
	<p><b>H8</b>   <b>H9</b> H8: Bypass flap H9: Pump combination or cooling battery</p>
	<p><b>H10</b>   <b>H11</b> H10: Pump re-heating battery H11: Pump combination or cooling battery</p>
	<p><b>H12</b>   <b>H13</b> H12A: Fault message (potential-free) H12B: Fault message (potential-free) H13: Not in use!</p>
	<p><b>H14</b>   <b>H15</b> Not in use!</p>
	<p><b>H16</b>   <b>H17</b> Not in use!</p>



ELECTRICAL CONNECTION DIAGRAM FOR THE MINI OR TOUCH CONTROL UNIT



Mini

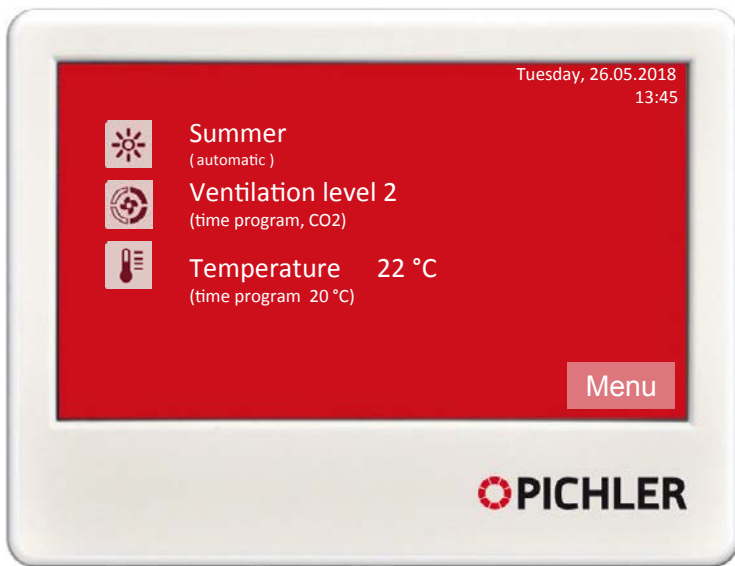

Touch Display

Rear control unit

A	B	GND	24VDC
1	2	3	4

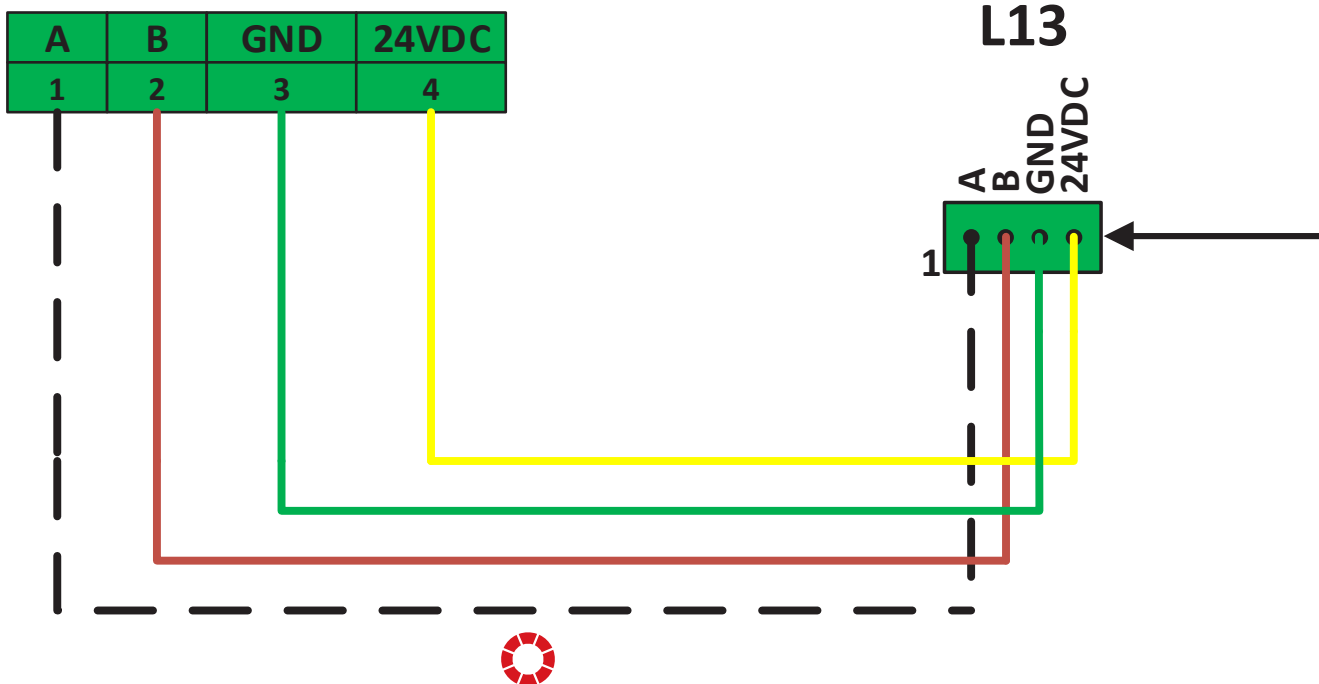

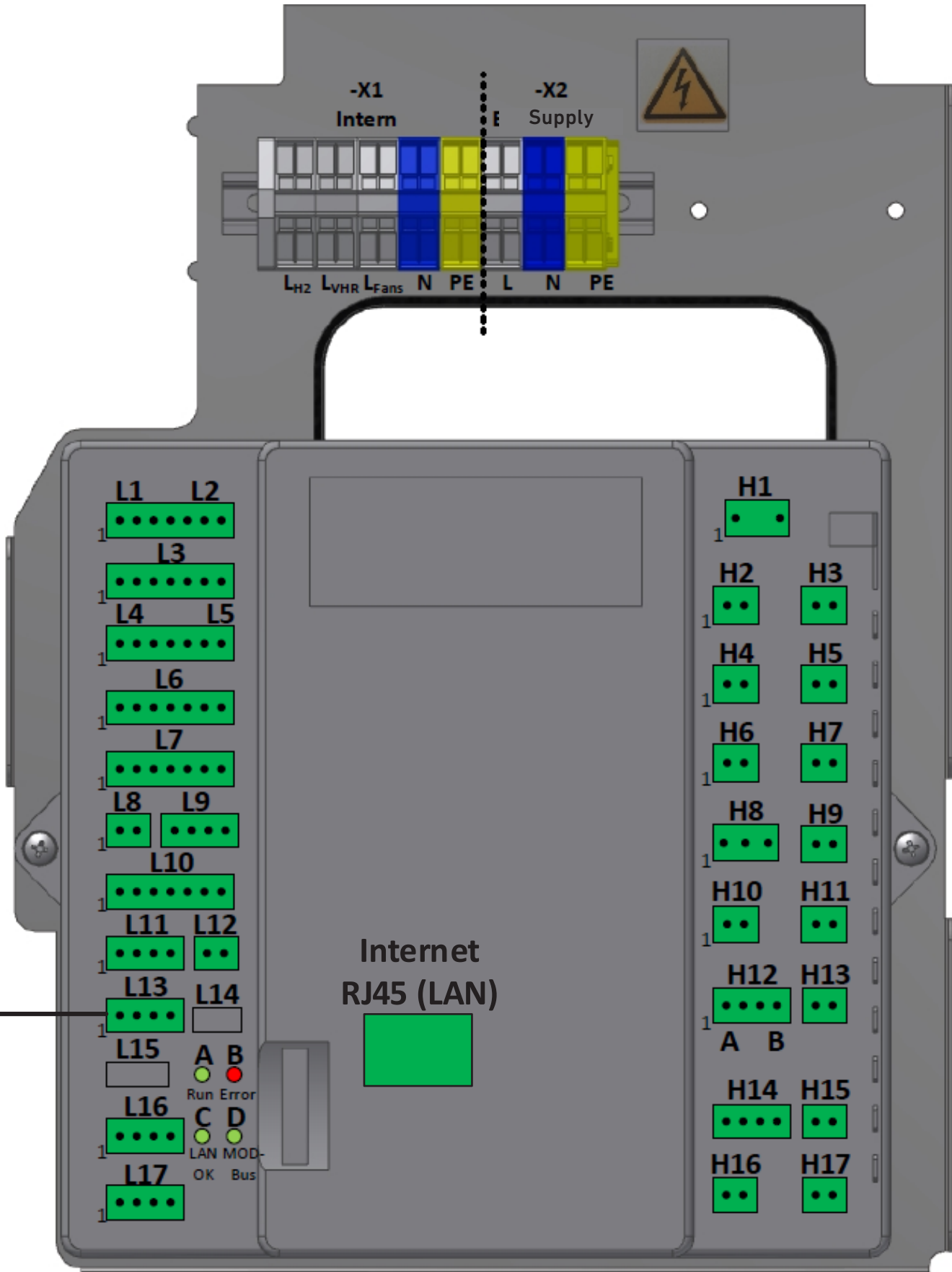

**ELECTRICAL CONNECTION DIAGRAM – EXTERNAL INPUTS**

**Digital input 1 (Di1)**

Used for external shutdown (external off), e.g. by a fire alarm control panel (fire alarm system). The contact is designed as a normally closed (NC) contact and is bridged when delivered.

**Digital input 2 (Di2)**

Serves for the external requirement of boost ventilation. If this contact (normally open, NO) is closed, the ventilation unit switches to fan speed 3. A run-on time of 30 minutes is set as standard for the boost ventilation function.

**Digital input 3 (Di3)**

Used to connect an external frost protection thermostat. If the contact (normally closed contact NC) is opened, the ventilation unit switches off with an error message. The error message "Frost protection (Di3)" is displayed on the touch display. This contact must be activated via the service software and is only checked if a re-heater battery is configured.

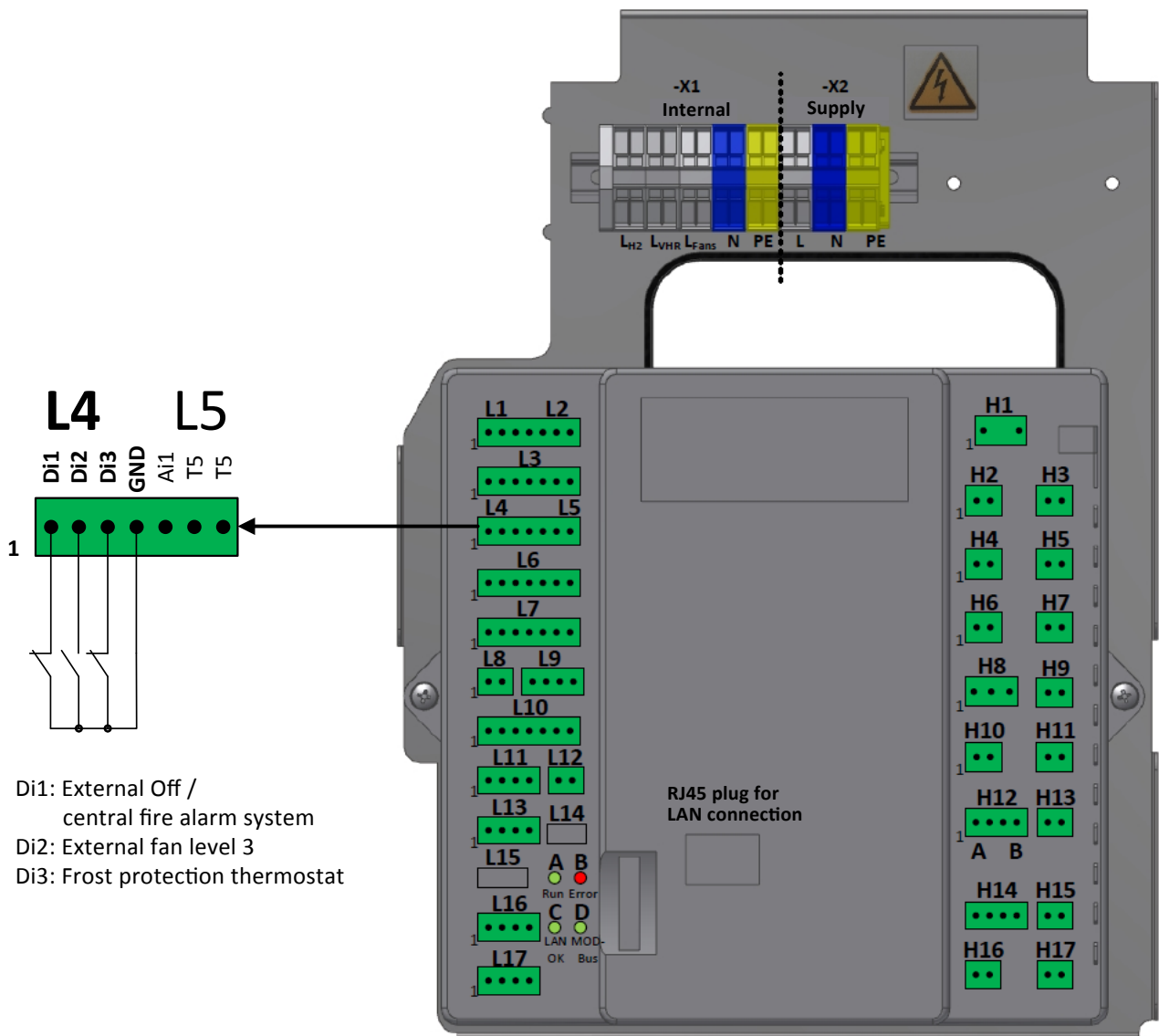

GENERAL

USER

SPECIALIST PERSONNEL



GENERAL

USER

**ELECTRICAL CONNECTION DIAGRAM – SHUT-OFF VALVES**

When the ventilation unit is switched off, its outdoor and exhaust air lines are closed by two motorised shut-off valves. Spring return actuators also ensure these

are closed during power outages. This ensures that no cold air can enter the system.

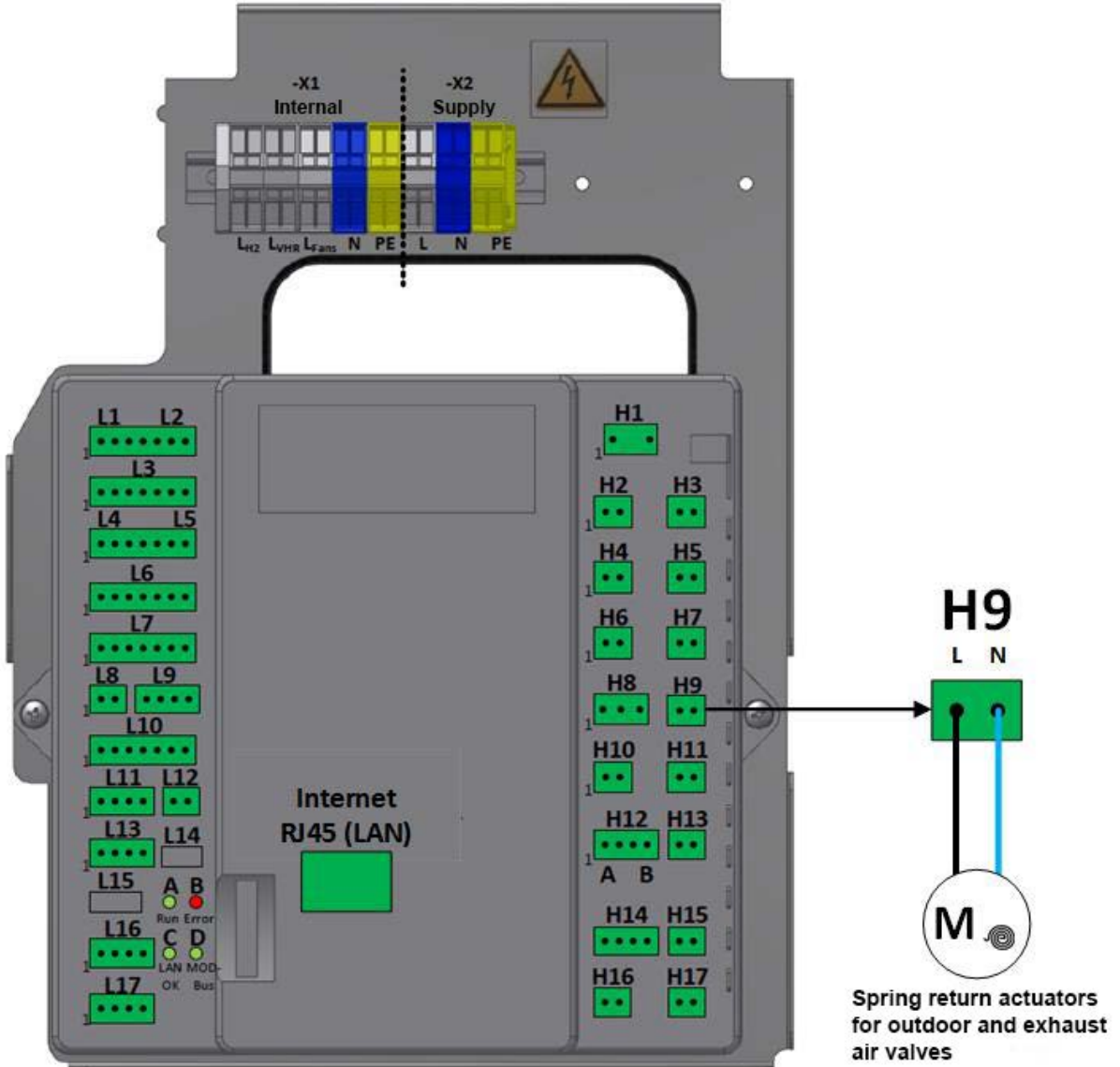

SPECIALIST PERSONNEL



### CONNECTING THE CONTROL UNIT TO THE CONTROL PCB

The controller consists of a control PCB and a control unit. The control PCB is to be connected to the control unit by means of a bus connection. The control PCB can communicate internal statuses as well as operating and fault messages to the control unit via this line connection.

A screened cable J-Y(ST)Y2x2x0.8 is required to establish the connection.

Cable length must not exceed 100 m. The screening must be connected to the ventilation unit's PE protective earthing. The connecting cable is included in the scope of supply.

The plug is connected to the control PCB and to the MINI or TOUCH control unit with a box header.

### MOUNTING THE MINI CONTROL UNIT



The MINI control unit does not have an integrated temperature sensor. This must be installed externally if required and connected to the control system.

The MINI control unit is installed by screwing the mounting bracket supplied into an ordinary electrical installation wall socket.

The control unit and cover frame are attached to the mounting bracket after plugging in the connection cable.

The mounting plate must be mounted on a flat surface using flat countersunk screws in order to ensure an optimum seat of all components.

### MOUNTING THE TOUCH CONTROL UNIT



*Illustration: TOUCH control unit wall mounting*



The temperature sensor is located on the bottom side of the control unit. To ensure accurate and conclusive temperature measurement it is important to place the control unit vertically in a location that:

- is not exposed to direct sunlight.
- is not located directly above or close to a direct source of heat (e.g. room heater).

The TOUCH control unit is installed by screwing the mounting bracket supplied into an ordinary electrical installation wall socket. The control unit and cover frame are attached to the mounting bracket after plugging in the connection cable.

Swiveling console: the TOUCH operating control unit can be attached directly to the ventilation unit on a swiveling console.



*Illustration: Swiveling console*

### CIRCULATING PUMPS

Pumps connected to the control system must be intrinsically safe and stall-proof. Electrical connection with  $U = 230 \text{ VAC}$  and  $I_{\text{max}} = 2 \text{ A}$ .



## 19. Maintenance and cleaning

### SAFETY INSTRUCTIONS



For all cleaning or servicing work on the ventilation unit, always pull the mains plug or fully (all poles) isolate from mains!

Other unit parts and components e.g. geothermal heat exchanger, pre- and re-heater battery, sound absorbers etc. must be serviced and cleaned in accordance with the regulations and instructions. Be acutely aware of hazards and safety when opening the front hood or covers. If possible, use a vacuum cleaner to remove dirt and dust. Applying force or

using compressed air for cleaning may damage components and surfaces.

Never use aggressive or solvent-containing cleaning agents.

The electrical components must not be exposed to moisture or wet conditions.

The safety information provided in the "Safety instructions" in **Section 4** and in particular the "Electrical connection work" item must be observed.

### MAINTENANCE INSTRUCTIONS



Only specialists are allowed to carry out the work specified below on the ventilation unit. Any defects detected during servicing must be remedied immediately to ensure

safe operation of the unit. Only original spare parts may be used for repairs and replacements.

### HEAT EXCHANGER

Annual cleaning is recommended at the least, depending on the degree of soiling of the heat exchanger.

In order to carry out the maintenance work, the heat exchanger must be removed carefully from the unit.

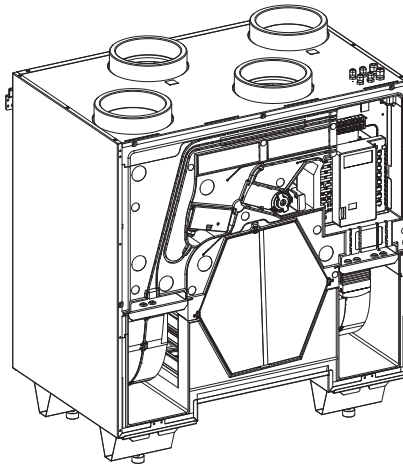

The heat exchanger is cleaned by rinsing with hot water (maximum 50 °C). Never blow through the exchanger with compressed air. This may damage the exchanger.

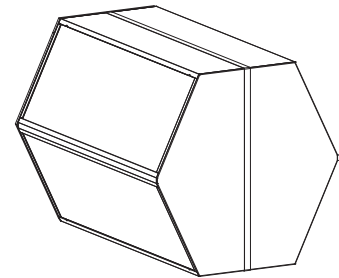

**FANS**



The motor housing must only be opened and work on the electrical components of the motor must only be performed by the fan manufacturer. If the fan is defective in any way, it must be replaced with a new, original fan.

Cleaning of the housing may be required depending on the degree of soiling of the fans.

Maintenance and cleaning work on the fan is exclusively restricted to the fan housing.

The fan unit must be carefully removed from the housing. Pay attention to the electrical connecting cable to the motor. It must not be damaged.

Avoid causing damage to the fan blades. Do not remove or damage wheel balance weights as this may cause an imbalance of the rotor which, in turn, may increase noise and vibration levels.

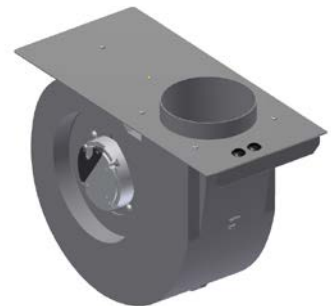
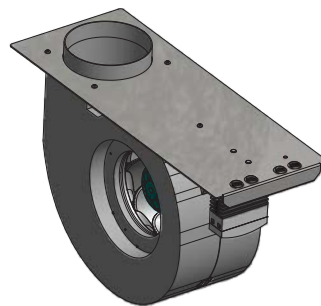

**ELECTRICAL PRE-HEATER BATTERY (OPTIONAL)**

Annual cleaning is recommended at the least, depending on the degree of soiling of the pre-heater battery.



Before commencing any work on the electrical heater batteries, the ventilation unit must be disconnected completely from the power supply (all poles) and secured against being switched back on!



For cleaning purposes, the pre-heater battery must be carefully removed from the ventilation unit. Pay attention to the electrical connection. It must not be damaged.

Use compressed air, a vacuum cleaner or a soft brush to remove dust.

When cleaning external electrical pre-heater batteries, it is essential that the prefilter is also checked (if present) and that it is replaced if soiled.



When the cleaning work has been completed, it must be ensured that the safety temperature limiter has not been activated.

GENERAL

USER

SPECIALIST PERSONNEL



**CLEANING THE INSIDE OF THE UNIT HOUSING**

We recommend cleaning at least once a year, depending on the level of soiling. Handle the housing surfaces with care during cleaning. Using excessive force

during cleaning, e.g. wiping or scrubbing, can cause damage to insulating surfaces. Preferably use a damp cloth or a vacuum cleaner to remove dust.

Electrical components may not be exposed to moisture or wet conditions. Be particularly careful not to damage the temperature sensors and the electrical wiring.

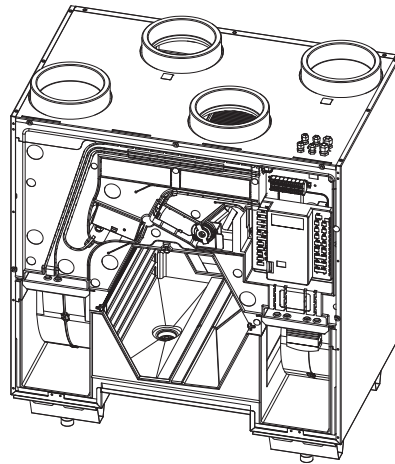
**CONDENSATE DRAINAGE**

Depending on the level of soiling and on temperatures, cleaning the condensate drain, drainage pipe and siphon at least once a year is recommended.

Fill the odour trap (siphon) with water before switching the unit back on to prevent unpleasant smells and leaks effectively.

The condensate drainage pipe and its components must operate perfectly to ensure proper operation of the unit. Remove any deposits or blockages in the discharge pipe and siphon. Clean the condensate cup with a damp cleaning cloth. It is essential that a functional test of the condensate drainage system is conducted after completion of cleaning.

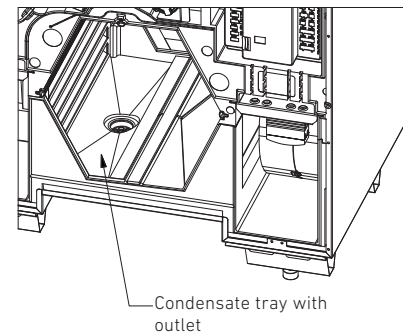

For this purpose, fill the condensate tray with a sufficient amount of water. Make sure that all of the water in the tray flows safely into the drain via the condensate drainage pipe. Ensure that the system is watertight.



**SERVICE TABLE**

In order to document maintenance works, this table must be completed after performance of works on the unit:

Unit commissioned by:			Date
No.	Maintenance work (e.g. filter change)	Performed by, signature	Date
1			
2			
3			
4			
5			
6			
7			
8			
9			
10			

GENERAL

USER

SPECIALIST PERSONNEL



GENERAL

USER

SPECIALIST PERSONNEL

11			
12			
13			
14			
15			
16			
17			
18			
19			
20			
21			
22			
23			
24			
25			



## SPECIALIST PERSONNEL - COMMISSIONING – SERVICE

### 20. Commissioning



The ventilation system must be complete, connected and ready for operation before it is put into operation for the first time. The unit can be put into operation and system settings can be configured only when all work on the system is complete.

The factory settings on the control unit may only be changed by a specialised company. Incorrect settings may cause the unit to malfunction.

Ventilation level	Operating mode	Designation	Volume flow LG 350	Recommendation for air change
Standby / basic ventilation		Depending on the configuration of the ventilation unit, the unit is in standby or basic ventilation mode with minimum ventilation of the building.	50 m <sup>3</sup> /h	-
1	Reduced ventilation	Reduced ventilation with minimum ventilation of the building	125 m <sup>3</sup> /h	Approx. 0.3 1/h
2	Standard ventilation	Ventilation level active if no other ventilation level has been selected manually or automatically	200 m <sup>3</sup> /h	Approx. 0.5 1/h
3	Intensive ventilation	Operation with increased volume flow, boost ventilation for short, intensive building ventilation	300 m <sup>3</sup> /h	Approx. 0.8 1/h

Ventilation level	Operating mode	Designation	Volume flow LG 450	Recommendation for air change
Standby / basic ventilation		Depending on the configuration of the ventilation unit, the unit is in standby or basic ventilation mode with minimum ventilation of the building.	50 m <sup>3</sup> /h	-
1	Reduced ventilation	Reduced ventilation with minimum ventilation of the building	180 m <sup>3</sup> /h	Approx. 0.3 1/h
2	Standard ventilation	Ventilation level active if no other ventilation level has been selected manually or automatically	290 m <sup>3</sup> /h	Approx. 0.5 1/h
3	Intensive ventilation	Operation with increased volume flow, boost ventilation for short, intensive building ventilation	400 m <sup>3</sup> /h	Approx. 0.8 1/h

**Ventilation level factory settings**

**BASIC STEPS OF THE COMMISSIONING PROCEDURE**

- Are all air ducts and components fully installed and airtight?
- Are all system components fitted and electrically connected?
- Is the electric wiring complete and the control unit fitted?
- Has the control unit been connected correctly electrically?
- Is the condensate drainage system complete?
- Are the air vents, inlet and outlet valves properly installed and open?
- Has the unit been aligned horizontally, in order to ensure reliable condensate drainage?
- Have the air filters in the ventilation unit been installed correctly and are they clean?
- Have the air filters in the geothermal heat exchanger, etc., been installed correctly and are they clean?
- Are the fire dampers used open (if applicable)?
- Have the extract air and exhaust air pipes been properly and sufficiently insulated?
- Has the safety temperature limiter of the pre-heater battery been reset?

**SETTING SYSTEM PARAMETERS**

- Check system components and correct settings where necessary.
- Set system parameters, e.g. adjust volume flow/ventilation level.
- Set time.
- Set time of day programs as required by the customer.
- System extensions correctly configured.



## 21. Error description

### MINI CONTROL UNIT

Error descriptions are provided for the corresponding light patterns in the following table. Errors can be located precisely using the

service software (available to specialist personnel only).

Pattern	Error
Error LED flashes once	Z05 (supply air fan), Z24, Z25 (supply air pressure), Z32
Error LED flashes twice	Z04 (exhaust air fan), Z26, Z27 (extract air pressure)
Error LED flashes 3 times	Z06, Z07, Z08, Z09, Z10, Z11, Z12, Z13 (temperature sensor)
Error LED flashes 4 times	Z01, Z03, Z21 (frost warning), Z28, Z31
Error LED flashes 5 times	Z14 (communication fans), Z22, Z23 (communication external sensors)
Error LED flashes 6 times	Z15 (low SUP-T), Z17 (low pre heater-T)

Filter LED lights up	Z16 (filter timer), Z29 (air filter SUP), Z30 (air filter ETA)
Error LED flashes on the Mini control unit / touch display shows no values	Z02 (control unit communication error), Bus interruption

Error	Description	Auto-reset
Z01	Temperature difference geothermal heat exchanger	
Z02	Control control unit	x
Z03	Post heater (Din3)	x
Z04	Extract air fan	
Z05	Supply air fan	
Z06	T1 - outdoor air	x
Z07	T2 - exhaust air	
Z08	T3 - extract air	x
Z09	T4 - supply air	
Z10	T5 - downstream of pre-heater battery	x
Z11	T6 - supply air downstream of batteries	x
Z12	T7 - external outdoor air temperature sensor	x
Z13	T8 - external room air temperature sensor	x
Z14	Fan communication	
Z15	Min. supply air temperature not reached	x
Z16	Filter message	
Z17	Pre-heater battery setpoint temperature not reached	
Z21	Post heater frost protection (SUP-T4 < 7 °C, SUP-T4 < 5 °C switch off of the unit)	x
Z22	Communication CO2 sensor	x
Z23	Communication pressure sensor	x
Z24	Low SUP duct pressure	x
Z25	High SUP duct pressure	x
Z26	Low ETA duct pressure	x
Z27	High ETA duct pressure	x
Z28 *	Danger of condensation	x
Z29 *	Air filter SUP	
Z30 *	Air filter ETA	
Z31 *	External Preheater alarm	
Z32 *	Door contact	x

\* only for LG 1000

Reset of non-autoreset errors by switching the air handling unit to "Standby" and restarting it.

### TOUCH CONTROL UNIT

Active errors are indicated as plain text on the TOUCH control unit. In addition, the errors are

documented in an error log. Please see *section 9 "Current errors" and "Error log"*.



## 22. Installation/operation of the service software and firmware updates

The control unit must be connected to a laptop via the micro USB cable in order to perform troubleshooting.

Further information on installation/operation of service software and firm-

ware updates is available from certified partners on request.

**Service hotline:** +43 (0)463 32769-290

**Email:** service@pichlerluft.at



Only original spare parts may be installed or used for replacements and repairs. Reliable

operation is ensured only if original spare parts are used!

## 23. Spare parts and accessories

### CONTROL ELEMENTS

Designation	Item number
STANDARD: operating control unit MINI for LG 350 and LG 450	08LGMINI350450
OPTIONAL: operating control unit TOUCH for LG 350 and LG 450	08LG350450T
OPTIONAL: Swivel bracket for attaching the TOUCH or MINI control unit directly to the ventilation unit	40LG350BG142
CO <sub>2</sub> sensor	07RCO248330
Humidity sensor	07RHF49360
Room temperature sensor	07RTF49357
Wireless room temperature, humidity and CO <sub>2</sub> sensor for surface installation	07MIWIRTRH
Wireless room temperature, humidity and CO <sub>2</sub> sensor for surface mounting	07MIWIRTRHCO2
Shielded connecting cable J-Y(ST)Y 2 x 2 x 0.8	40LG040340

### SYSTEM COMPONENTS LG 350

Designation	Item number
Combination battery (cold water battery) for duct installation ø 160 mm	01CWK160
Warm water heater battery for duct installation ø 160 mm	01VBC160
DN15 KVS 0.63 three-way valve with LR24ASR actuator	07R3015P6LR24ASR
Temperature sensor with metal sleeve (NTC thermistor sensor), length 2 m	40LG041920
External electric re-heating battery, 1.200 Watt	08CV16121VICIAL
Shut-off valve AKR Ø 160 mm with motor LF 230	02AKR160LF230

### SYSTEM COMPONENTS LG 450

Designation	Item number
Combination battery (cold water battery) for duct installation ø 200 mm	01CWK200
Warm water heater battery for duct installation ø 200 mm	01VBC200
DN15 KVS 1.00 three-way valve with LR24ASR actuator	07R30151SLR24ASR
Temperature sensor with metal sleeve (NTC thermistor sensor), length 2 m	40LG041920
External electric re-heating battery, 1.200 Watt	08CV16121VICIAL
Shut-off valve AKR Ø 200 mm with motor LF 230	02AKR200LF230

### AIR FILTERS

Designation	Item number
Extract air filter ISO ePM1 60 %	40LG0500000A
Outdoor air filter ISO COARSE 80 %	40LG0500001A

### ACCESSORIES

Designation	Item number
Condensate siphon HL 136.3 DN 40 x 5/4"	40LG030620
Condensate pump for automatic extraction of condensate	02CONLIFT1

### GATEWAY

Designation	Item number
MODBUS/KNX-GATEWAY	08KNXGAC
MODBUS/MiWi-GATEWAY	07GATEWAYMIWI
BACnet-GATEWAY	08BACGAES2020

## 24. Changes reserved

It is our constant endeavour to technically improve and optimise our products and we reserve the right to change the design

of the units or the technical specifications without prior notice.



## 25. Product data sheets

## Ventilation unit: LG 350

### PRODUCT DATA SHEET LG 350

Specific energy consumption (SEC)	manual control		clock control	central demand control	local demand control	[kWh/(m <sup>2</sup> ·a)]
	cold climate	-79,6	-80,4	-81,9	-84,6	
average climate	-40,3	-41,0	-42,3	-44,5		
warm climate	-15,2	-15,8	-17,0	-19,0		

Specific energy consumption class	A	A	A+ (most efficient)	A+ (most efficient)
-----------------------------------	---	---	------------------------	------------------------

#### Type

"residential ventilation system", "bidirectional ventilation system"

#### Motor and drive

variable speed	x-value	2 [-]
----------------	---------	-------

#### Type of heat recovery system

recuperative

Thermal efficiency of heat recovery	$\eta_t$	92,8% [-]
-------------------------------------	----------	-----------

Maximum flow rate	$q_{Vd}$	350 [m <sup>3</sup> /h]
-------------------	----------	-------------------------

#### Electric power input of the fan drive, including any motor control equipment, at maximum flow rate

$P_E$	102,4 [W]
-------	-----------

Sound power level	$L_{WA}$	37,7 [dB(A)]
-------------------	----------	--------------

Reference flow rate	$q_{Vn}$	245 [m <sup>3</sup> /h]
---------------------	----------	-------------------------

Reference pressure difference	$P_{tU}$	50 [Pa]
-------------------------------	----------	---------

Specific power input	SPI	0,19 [W/(m <sup>3</sup> /h)]
----------------------	-----	------------------------------

#### Ventilation control (CTRL)

local demand control	1	0,95	0,85	0,65	[-]
----------------------	---	------	------	------	-----

#### Maximum air leakage rate referred to reference flow rate

internal	$q_{vi} / q_{Vn}$	0,33% [-]
external	$q_{ve} / q_{Vn}$	0,78% [-]

#### Filter change

The filters are to be replaced as soon as the command to replace the filters appears on the display of the operator control unit. (marked red in the pictures alongside)

#### CAUTION:

If the filters are not changed regularly, the system can not work efficiently and the power consumption increases.



Operator control unit "MINI"



Operator control unit "TOUCH"

#### Waste disposal

Units that are no longer in working order have to be dismantled and properly disposed of by a specialized company via suitable collection centres and in compliance with the waste electrical and electronic equipment ordinance (WEEE), which provides for ratification of community law, directive 202/95/EC (RoHS) and the directive 2002/96/EC (the WEEE directive).

Annual electricity consumption (AEC)	2,8	2,6	2,2	1,5	[kWh/m <sup>2</sup> a]
--------------------------------------	-----	-----	-----	-----	------------------------

#### Annual heating saved (AHS)



cold climate	91,4	91,6	92,1	92,9	[kWh primary energy/a]
average climate	46,7	46,8	47,1	47,5	[kWh primary energy/a]
warm climate	21,1	21,2	21,3	21,5	[kWh primary energy/a]

Information based on the current state of knowledge of EU Regulations 1253/2014 and 1254/2014

Download from: [www.pichlerluft.at](http://www.pichlerluft.at)



## PRODUCT DATA SHEET LG 350F

	manual control	clock control	central demand control	local demand control	
<b>Specific energy consumption (SEC)</b>					
cold climate	-78,8	-79,9	-82,1	-86,0	[kWh/(m <sup>2</sup> ·a)]
average climate	-37,7	-38,5	-40,1	-42,9	[kWh/(m <sup>2</sup> ·a)]
warm climate	-14,1	-14,8	-16,0	-18,1	[kWh/(m <sup>2</sup> ·a)]
<b>Specific energy consumption class</b>					
	A	A	A	A+	(most efficient)
<b>Type</b>					
"residential ventilation system", "bidirectional ventilation system"					
<b>Motor and drive</b>					
variable speed			x-value	2	[-]
<b>Type of heat recovery system</b>					
recuperative					
<b>Thermal efficiency of heat recovery</b>					
			$\eta_t$	81,2%	[-]
<b>Maximum flow rate</b>					
			$q_{Vd}$	350	[m <sup>3</sup> /h]
<b>Electric power input of the fan drive, including any motor control equipment, at maximum flow rate</b>					
			$P_E$	93,1	[W]
<b>Sound power level</b>					
			$L_{WA}$	37,7	[dB(A)]
<b>Reference flow rate</b>					
			$q_{Vn}$	245	[m <sup>3</sup> /h]
<b>Reference pressure difference</b>					
			$p_{tU}$	50	[Pa]
<b>Specific power input</b>					
			SPI	0,17	[W/(m <sup>3</sup> /h)]
<b>Ventilation control (CTRL)</b>					
local demand control	1	0,95	0,85	0,65	[-]
<b>Maximum air leakage rate referred to reference flow rate</b>					
internal			$q_{vi} / q_{Vn}$	0,57%	[-]
external			$q_{ve} / q_{Vn}$	0,78%	[-]
<b>Filter change</b>					
The filters are to be replaced as soon as the command to replace the filters appears on the display of the operator control unit. (marked red in the pictures alongside)					
CAUTION: If the filters are not changed regularly, the system can not work efficiently and the power consumption increases.					
					
		Operator control unit "MINI"		Operator control unit "TOUCH"	
<b>Waste disposal</b>					
Units that are no longer in working order have to be dismantled and properly disposed of by a specialized company via suitable collection centres and in compliance with the waste electrical and electronic equipment ordinance (WEEE), which provides for ratification of community law, directive 202/95/EC (RoHS) and the directive 2002/96/EC (the WEEE directive).					
<b>Annual electricity consumption (AEC)</b>					
	2,1	1,9	1,5	0,9	[kWh/m <sup>2</sup> ·a]
<b>Annual heating saved (AHS)</b>					
cold climate	84,2	84,7	85,9	88,3	[kWh primary energy/a]
average climate	43,0	43,3	43,9	45,1	[kWh primary energy/a]
warm climate	19,5	19,6	19,9	20,4	[kWh primary energy/a]

Information based on the current state of knowledge of EU Regulations 1253/2014 and 1254/2014

Download from: [www.pichlerluft.at](http://www.pichlerluft.at)

## PRODUCT DATA SHEET LG 450

Specific energy consumption (SEC)	manual control		clock control	central demand control	local demand control	[kWh/(m <sup>2</sup> ·a)]
cold climate	-76,9		-77,9	-79,9	-83,2	
average climate	-38,2		-39,1	-40,7	-43,5	
warm climate	-13,4		-14,2	-15,7	-18,2	

Specific energy consumption class	A	A	A	A+ (most efficient)
-----------------------------------	---	---	---	---------------------

**Type**

"residential ventilation system", "bidirectional ventilation system"

**Motor and drive**

variable speed x-value 2 [-]

**Type of heat recovery system**

recuperative

**Thermal efficiency of heat recovery**

$\eta_t$  90,9% [-]

**Maximum flow rate**

$q_{Vd}$  450 [m<sup>3</sup>/h]

**Electric power input of the fan drive, including any motor control equipment, at maximum flow rate**

$P_E$  166,7 [W]

**Sound power level**

$L_{WA}$  42,9 [dB(A)]

**Reference flow rate**

$q_{Vn}$  315 [m<sup>3</sup>/h]

**Reference pressure difference**

$p_{tU}$  50 [Pa]

**Specific power input**

SPI 0,24 [W/(m<sup>3</sup>/h)]

**Ventilation control (CTRL)**

local demand control 1 0,95 0,85 0,65 [-]

**Maximum air leakage rate referred to reference flow rate**

internal  $q_{vi} / q_{Vn}$  0,25% [-]  
external  $q_{ve} / q_{Vn}$  0,60% [-]

**Filter change**

The filters are to be replaced as soon as the command to replace the filters appears on the display of the operator control unit. (marked red in the pictures alongside)

**CAUTION:**

If the filters are not changed regularly, the system can not work efficiently and the power consumption increases.



Operator control unit "MINI"



Operator control unit "TOUCH"

**Waste disposal**

Units that are no longer in working order have to be dismantled and properly disposed of by a specialized company via suitable collection centres and in compliance with the waste electrical and electronic equipment ordinance (WEEE), which provides for ratification of community law, directive 202/95/EC (RoHS) and the directive 2002/96/EC (the WEEE directive).

Annual electricity consumption (AEC)	3,4	3,1	2,6	1,7	[kWh/m <sup>2</sup> ·a]
--------------------------------------	-----	-----	-----	-----	-------------------------

**Annual heating saved (AHS)**



cold climate	90,2	90,5	91,0	92,2	[kWh primary energy/a]
average climate	46,1	46,3	46,5	47,1	[kWh primary energy/a]
warm climate	20,8	20,9	21,00	21,3	[kWh primary energy/a]

Information based on the current state of knowledge of EU Regulations 1253/2014 and 1254/2014

Download from: [www.pichlerluft.at](http://www.pichlerluft.at)



## PRODUCT DATA SHEET LG 450F

	manual control	clock control	central demand control	local demand control	
<b>Specific energy consumption (SEC)</b>					
cold climate	-76,0	-77,3	-79,8	-84,5	[kWh/(m <sup>2</sup> ·a)]
average climate	-35,6	-36,6	-38,5	-41,8	[kWh/(m <sup>2</sup> ·a)]
warm climate	-12,5	-13,3	-14,8	-17,4	[kWh/(m <sup>2</sup> ·a)]
<b>Specific energy consumption class</b>	A	A	A	A	
<b>Type</b>					
"residential ventilation system", "bidirectional ventilation system"					
<b>Motor and drive</b>					
variable speed			x-value	2 [-]	
<b>Type of heat recovery system</b>					
recuperative					
<b>Thermal efficiency of heat recovery</b>					
			$\eta_t$	78,7% [-]	
<b>Maximum flow rate</b>					
			$Q_{Vd}$	450 [m <sup>3</sup> /h]	
<b>Electric power input of the fan drive, including any motor control equipment, at maximum flow rate</b>					
			$P_E$	152,7 [W]	
<b>Sound power level</b>					
			$L_{WA}$	42,9 [dB(A)]	
<b>Reference flow rate</b>					
			$Q_{Vn}$	315 [m <sup>3</sup> /h]	
<b>Reference pressure difference</b>					
			$P_{tU}$	50 [Pa]	
<b>Specific power input</b>					
			SPI	0,21 [W/(m <sup>3</sup> /h)]	
<b>Ventilation control (CTRL)</b>					
local demand control	1	0,95	0,85	0,65	[-]
<b>Maximum air leakage rate referred to reference flow rate</b>					
internal			$q_{vi} / q_{Vn}$	0,44% [-]	
external			$q_{ve} / q_{Vn}$	0,60% [-]	
<b>Filter change</b>					
The filters are to be replaced as soon as the command to replace the filters appears on the display of the operator control unit. (marked red in the pictures alongside)					
CAUTION: If the filters are not changed regularly, the system can not work efficiently and the power consumption increases.					
					
		Operator control unit "MINI"		Operator control unit "TOUCH"	
<b>Waste disposal</b>					
Units that are no longer in working order have to be dismantled and properly disposed of by a specialized company via suitable collection centres and in compliance with the waste electrical and electronic equipment ordinance (WEEE), which provides for ratification of community law, directive 202/95/EC (RoHS) and the directive 2002/96/EC (the WEEE directive).					
<b>Annual electricity consumption (AEC)</b>					
	2,6	2,4	1,9	1,1	[kWh/m <sup>2</sup> ·a]
<b>Annual heating saved (AHS)</b>					
cold climate	82,6	83,3	84,6	87,2	[kWh primary energy/a]
average climate	42,2	42,6	43,2	44,6	[kWh primary energy/a]
warm climate	19,1	19,2	19,6	20,2	[kWh primary energy/a]

Information based on the current state of knowledge of EU Regulations 1253/2014 and 1254/2014

Download from: [www.pichlerluft.at](http://www.pichlerluft.at)

## 26. EC Declaration of Conformity

<b>Hersteller / Manufacturer:</b>	J. Pichler Gesellschaft m.b.H.
<b>Anschrift / Address:</b>	Karlweg 5 9021 Klagenfurt am Wörthersee
<b>Bezeichnung / Product description:</b>	Ventilation unit in compact design with an integrated control system
<b>Ausführungen / Type:</b>	LG 350 / LG 350 V / LG 350 F / LG 350 FV LG 450 / LG 450 V / LG 450 F / LG 450 FV with MINI or TOUCH control unit

**Die bezeichneten Produkte stimmen in der von uns in Verkehr gebrachten Ausführung mit den Vorschriften folgender europäischen Richtlinien überein:**

*The products described above in the form as delivered are in conformity with the provisions of the following European Directives:*

<b>2014/35/EU</b>	Zur Harmonisierung der Rechtsvorschriften der Mitgliedsstaaten über die Bereitstellung elektrischer Betriebsmittel zur Verwendung innerhalb bestimmter Spannungsgrenzen auf dem Markt <i>On the harmonisation of the laws of the Member States relating to the making available on the market of electrical equipment designed for use within certain voltage limits</i>
<b>2014/30/EG</b>	Zur Harmonisierung der Rechtsvorschriften der Mitgliedstaaten über die elektromagnetische Verträglichkeit <i>On the harmonisation of the laws of the Member States relating to electromagnetic compatibility</i>
<b>2009/125/EG</b>	Richtlinie des Europäischen Parlaments und des Rates zur Angleichung der Rechtsvorschriften der Mitgliedsstaaten zur Schaffung eines Rahmens für die Festlegung von Anforderungen an die umweltgerechte Gestaltung energieverbrauchsrelevanter Produkte <i>Council Directive on the approximation of the laws of the Member States establishing a framework for the setting of ecodesign requirements for energy-related products</i>

**Die Konformität mit den Richtlinien wird nachgewiesen durch die Einhaltung folgender Normen und Verordnungen:**

*Conformity to the Directives is assured through the application of the following standards and regulations:*

**VO 1253/2014/EU Verordnung (EU) der Kommission zur Durchführung der Richtlinie 2009/125/EG des Europäischen Parlaments und des Rates hinsichtlich der Anforderungen an die umweltgerechte Gestaltung von Lüftungsanlagen**

*COMMISSION REGULATION (EU) implementing Directive 2009/125/EC of the European Parliament and of the Council with regard to ecodesign requirements for ventilation units*

**VO 1254/2014/EU zur Ergänzung der Richtlinie 2010/30/EU des Europäischen Parlaments und des Rates im Hinblick auf die Kennzeichnung von Wohnraumlüftungsgeräten in Bezug auf den Energieverbrauch**

*VO 1254/2014/EU supplementing Directive 2010/30/EU of the European Parliament and of the Council with regard to energy labelling of residential ventilation units*

ÖVE / ÖNORM EN 60335-1	ÖVE / ÖNORM EN 62233
ÖVE / ÖNORM EN 60335-2-30 (analogously)	ÖVE / ÖNORM EN 55014-1
ÖVE / ÖNORM EN 60335-2-65 (analogously)	ÖVE / ÖNORM EN 55014-2
ÖVE / ÖNORM EN 60335-2-80 (analogously)	ÖVE / ÖNORM EN 61000-3-2
ÖVE / ÖNORM EN 50366	ÖVE / ÖNORM EN 61000-3-3

**Eine vom Lieferzustand abweichende Veränderung des Gerätes führt zum Verlust der Konformität.**

*Product modifications after delivery may result in a loss of conformity.*

**Diese Erklärung bescheinigt die Übereinstimmung mit den genannten Richtlinien, ist jedoch keine Zusicherung von Eigenschaften. Die Sicherheitsinformationen der mitgelieferten Produktdokumentation sind zu beachten.**

*This declaration certifies the conformity to the specified directives but contains no assurance of properties. The safety documentation accompanying the product shall be considered in detail.*

J. Pichler Gesellschaft m.b.H.  
Geschäftsleitung / General Manager

Klagenfurt, 1 October 2018



**ErP 2018**

Fulfills the requirements of the Ecodesign Directive in accordance with EU Regulation 1253/2014.



**EPREL**

Our LG 350 / LG 450 compact ventilation unit is listed in the EPREL - European Product Database for Energy Labelling.



*Responsible for the content:* J. Pichler Gesellschaft m.b.H.

*Photos:* Ferdinand Neumüller, Archiv J. Pichler Gesellschaft m.b.H. | *Text:* J. Pichler Gesellschaft m.b.H.  
All rights reserved | All photos are generic photos | Subject to change without notice | *Version:* 07/2025 eh



*Systematic ventilation.*

**J. PICHLER**  
Gesellschaft m.b.H.  
office@pichlerluft.at  
www.pichlerluft.at

**AUSTRIA**  
**9021 KLAGENFURT**  
**AM WÖRTHERSEE**  
Karlweg 5  
T +43 (0)463 32769  
F +43 (0)463 37548

**AUSTRIA**  
**1100 WIEN**  
Doerenkampgasse 5  
T +43 (0)1 6880988  
F +43 (0)1 6880988-13

Sales offices  
in Slovenia and Serbia.  
Sales partners Europe.